

Operating Instructions

BA 9733 EN 10.04

Oil supply systems of type **OWGX**

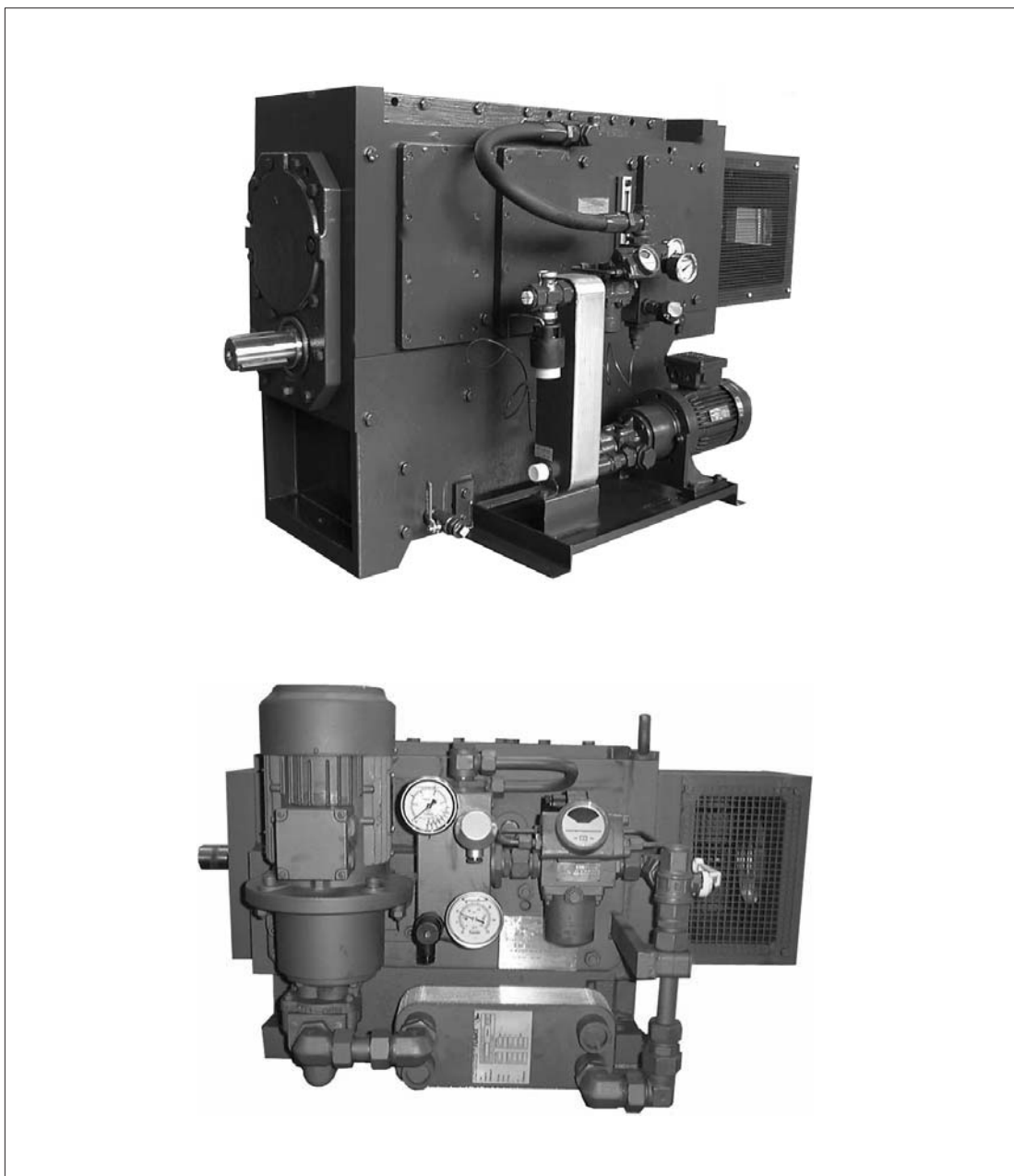

FLENDER

Contents

1.	Technical data	4
1.1	General technical data	4
1.2	Oil viscosity / oil type	4
2.	General notes	5
2.1	Introduction	5
2.2	Copyright	5
3.	Safety notes	6
3.1	Proper use	6
3.2	Obligations of the user	6
3.3	Environmental protection	7
3.4	Special dangers	7
3.5	Warnings and symbols used in these Instructions	7
4.	Handling and storage	7
4.1	Scope of supply	7
4.2	Handling	7
4.3	Storage of the oil supply system	8
4.4	Standard corrosion protection	8
5.	Technical description	9
5.1	General	9
6.	Assembly	10
6.1	General	10
6.2	General notes on add-on components	10
6.3	Final installation work	10
7.	Start-up	11
7.1	Oil filling	11
7.2	Pump	11
7.3	Water oil-cooler	11
7.4	Start-up	12
7.5	Removal from service	12
7.5.1	Interior protection with preservative agent	12
7.5.2	Interior preservation procedure	13

8.	Operation	13
8.1	Lubrication diagram	13
8.2	Control information	13
8.2.1	Pump (10)	13
8.2.2	Filter (20)	13
8.2.3	Three-way cock (17)	13
8.2.4	Pressure gauge (45)	14
8.2.5	Pressure monitor (50)	14
8.2.6	Thermometer (60)	14
8.2.7	Resistance thermometer (65)	14
8.2.8	Temperature monitor (70)	14
8.2.9	Cooling-water flow regulator (500)	14
8.2.10	General	14
8.3	Interlocking instructions	14
8.3.1	Gear unit enable	14
8.3.2	Warning	14
8.3.3	Gear unit stop	14
8.4	Response to malfunctions	15
8.5	Shut-down	15
9.	Faults, causes and remedy	15
9.1	General information on faults and malfunctions	15
9.2	Possible faults	16
10.	Maintenance and repair	17
10.1	Oils	17
10.2	Pump	17
10.3	Filter	17
10.4	Water oil-cooler	17
10.5	Preservation	17
11.	Spare parts, customer-service addresses	18
11.1	Stocking spare parts	18
11.2	Spare-part and customer-service addresses	18
12.	Declaration by the manufacturer	24

1. Technical data

1.1 General technical data

The most important technical data on the oil supply system are shown on the rating plate. These data and the contractual agreements between FLENDER and the customer for the oil supply system determine the limits of its correct use.

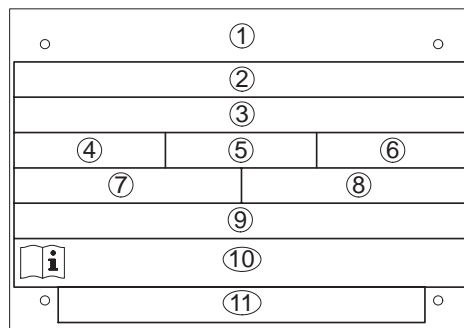

- ① Company logo and production location
- ② Material No.
- ③ Production order no.
- ④ Type
- ⑤ Size
- ⑥ Variant
- ⑦ $p_{\text{Oil max}}$ = max. permissible oil operating overpressure
- ⑧ t_{min} = minimum starting temperature
- ⑨ perm. operating pressure of the water: $P_{\text{Water max.}}$... bar / ... PSI
- ⑩ Operating Instructions number
- ⑪ special data (eg. total weight)

Note: These operating instructions generally include a list of equipment including the drawings to the oil supply system and the operating instructions for the accessory components.

For further technical data, refer to the list of equipment and the drawings.

1.2 Oil viscosity / oil type

For the oil viscosity and oil type, refer to the operating instructions or the gear unit rating plate.

The oil supply systems are designed for oil viscosities < 5000 cSt at minimum starting temperature (see rating plate ⑦).

2. General notes

2.1 Introduction

These Operating Instructions (BA) are an integral part of the delivery of the oil supply system and must be kept in its vicinity for reference at all times.

Note: Please also observe the Operating Instructions of the gear unit.

Caution!

All persons involved in the installation, operation, maintenance and repair of the oil supply system must have read and understood these Operating Instructions and must comply with them at all times. We accept no responsibility for damage or disruption caused by disregard of these Instructions.

The "FLENDER oil supply system" dealt with in these Operating Instructions (BA) has been developed for use as an oil supply system of gear units. Possible applications for oil supply system of this series are the chemical, rubber, food plastics and other industries.

The oil supply system is designed only for the application described in section 1, "Technical data" and the List of Equipment. Other operating conditions must be contractually agreed.

The oil supply system described in these Instructions reflects the state of technical development at the time these Instructions (BA) went to print.

In the interest of technical progress we reserve the right to make changes to the individual assemblies and accessories which we regard as necessary to preserve their essential characteristics and improve their efficiency and safety.

2.2 Copyright

The copyright to these Operating Instructions (BA) is held by **FLENDER AG**.

These Operating Instructions must not be wholly or partly reproduced for competitive purposes, used in any unauthorised way or made available to third parties without our agreement.

Technical enquiries should be addressed to the following works

A. FRIEDR. FLENDER AG
D-46393 Bocholt

Tel.: 02871/92-0
Fax: 02871/92-2728

or to one of our customer-service addresses. A list of our customer-service addresses is given in section 11, "Spare parts, customer-service addresses".

3. Safety notes

Note: Please also observe the Operating Instructions of the gear unit.

3.1 Proper use

- The oil supply system has been manufactured in accordance with the state of the art and is delivered in a condition for safe and reliable use. Any changes on the part of the user which may affect safety and reliability are prohibited. This applies equally to safety features designed to prevent accidental contact.
- The oil supply system must be used and operated strictly in accordance with the conditions laid down in the contract governing performance and supply agreed by FLENDER and the customer.

3.2 Obligations of the user

- The operator must ensure that all persons involved in installation, operation, maintenance and repair have read and understood these Operating Instructions and comply with them at all times in order to:
 - avoid injury or damage,
 - ensure the safety and reliability of the oil supply system,and
 - avoid disruptions and environmental damage through incorrect use.
- During transport, assembly, installation, dismantling, operation and maintenance of the unit, the relevant safety and environmental regulations must be complied with at all times.
- The oil supply system must be operated, maintained or repaired only by authorised, duly trained and qualified personnel.
- The gear unit must not be cleaned using high-pressure cleaning equipment.
- All work must be carried out with great care and with due regard to safety.
- All work on the oil supply system must be carried out only when it is at a standstill. The drive unit must be secured against being switched on accidentally (e.g. by locking the key switch or removing the fuses from the power supply). A notice should be attached to the ON switch stating clearly that work on the oil supply system is in progress.
- If any changes are noticed during operation of the oil supply system (e.g. increased operating temperature or unusual noises), the drive assembly must be switched off immediately.
- Rotating drive components such as couplings, gearwheels, belt drives etc. must be protected against accidental contact.
- If the oil supply system is intended for mounting on plant or equipment, the manufacturer of such plant or equipment must ensure that the contents of the present Operating Instructions are incorporated in his own instructions.
- Notices attached to the oil supply system, e.g. rating plate, direction arrows etc. must always be observed. They must be kept free from dirt and paint at all times. Missing plates must be replaced.
- All spare parts must be obtained from FLENDER.

3.3 Environmental protection

- When changing oil, the used oil must be collected in suitable containers. Any spillage of oil must be removed immediately.
- Preservative agent should be stored separately from used oil.
- Used oil, preservative agent, oil-binding agents and oil-soaked cloths must be disposed of in accordance with environmental legislation.

3.4 Special dangers

Depending on operating conditions, the surface of the oil supply system may heat up considerably.
Danger of burns!

- When changing oil, take care to prevent scalding by hot oil.

3.5 Warnings and symbols used in these Instructions



This symbol indicates safety measures which must be observed to avoid **personal injury**.

Caution!

This symbol refers to safety measures which must be observed to avoid **damage to the oil supply system and gear unit**.

Note: This symbol indicates general **operating instructions** which are of particular importance.

4. Handling and storage

Note: Observe the "Safety instructions" in section 3.

Note: Please also observe the Operating Instructions of the gear unit.

4.1 Scope of supply

The products supplied are listed in the despatch papers. Check immediately on receipt to ensure that all the products listed have actually been delivered. Parts damaged during transport or missing parts must be reported in writing immediately to FLENDER AG.

4.2 Handling



When handling FLENDER products, use only lifting and handling equipment of sufficient load-bearing capacity!

The oil supply system is delivered in the fully assembled condition. Additional items are delivered separately packaged. Depending upon the individual application, they can also be assembled to the gear unit and delivered with it as an assembled unit.

Different forms of packaging may be used depending on the size of the oil supply system / assembled unit and method of transport. Unless otherwise agreed, the packaging complies with the **HPE Packaging Guidelines**.

The symbols marked on the packaging must be observed at all times. These have the following meanings:

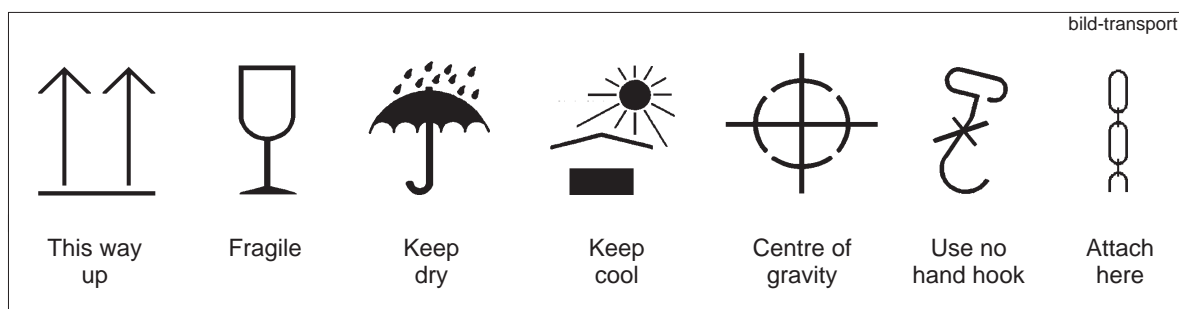

Caution!

The oil supply system or assembled unit must always be transported with due care to avoid injury to persons and damage to the unit.

Note:

The oil supply system or assembled unit must be transported using suitable transport equipment only.

Never transport the gear unit with an oil filling.

Caution!

To transport and handle gear units with attached oil supply systems, use only the lifting eyes specially provided for this purpose on the gear units. The position of the attachment points is shown in the documentation of the gear unit for each specific order.

Caution!

When handling the separate oil supply system, exercise special care to avoid damage due to the use of force or careless loading and unloading.

To transport and handle the oil supply system, use ropes or chains. Only the designated lifting eyes on the base frame must be used for fastening.

Care must be taken that the carrier ropes do not damage fittings and piping. A cross-beam is therefore required for protection. The lengths of the ropes must be set to ensure that the base frame is suspended horizontally.

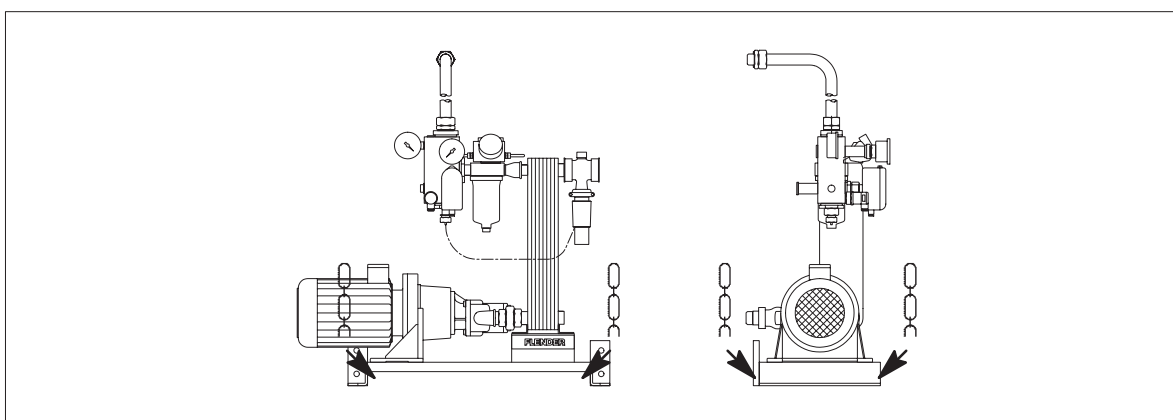

4.3 Storage of the oil supply system

The oil supply system or assembled unit must be stored in the position of use on a vibration-free wooden base in a sheltered place and covered over.



Do not stack oil supply systems or assembled units one on top of another.

Caution!

If the oil supply system or assembled unit is being stored out of doors, it must be very carefully covered over and care must be taken that neither moisture nor foreign material can collect on the drive.

Note:

Provision for special environmental conditions during transport (e.g. transport by ship) and storage (climate, termites, etc.) must be contractually agreed.

The openings must be sealed with plugs or flanged covers.

4.4 Standard corrosion protection

The properties of the outer paint coat are as follows: Resistant to acids, weak alkalis, solvents, atmospheric action, temperatures up to 120 °C (temporarily up to 140 °C) and to tropical conditions.

Note:

Unless otherwise contractually agreed, the internal preservation is guaranteed for 6 months, provided that storage is in dry, frostfree sheds.

The guarantee period starts on the date of delivery.

For longer periods of storage (> 6 months) we advise regular checking and, if necessary, renewal of the internal preservation (see section 7, "Start-up").

5. Technical description

Note: Observe the "Safety instructions" in section 3.

5.1 General

Note: Please also observe the Operating Instructions of the gear unit.

The oil supply system specified below serves to cool the oil and/or lubricate gear units (see section 1, "Technical Data").

Caution!

Before initial start-up the pressure monitor, the temperature monitoring system and the differential pressure monitor installed in the filter must be connected up.

- The oil supply is ensured by a battery of pumps.
- The pump sucks the oil out of the gear unit oil sump via a suction pipe.
- A filter to filter the circulating oil is installed in the oil circuit.
- Heat generated by losses and not removable by convection is removed via a water oil-cooler.
- Filtered and re-cooled oil is then resupplied to the gear unit via a pressure line.

Note: For control instructions, refer to section 8, "Operation".

Observe for this the drawings and the list of equipment. The components specified in the list of equipment can also be found on the drawings with the part number.

Note: The direction of discharge of the pump used is **dependent upon the direction of rotation**.

Caution!

To ensure optimum cooling performance, the specified direction of flow in the water oil-cooler must be observed. The cooling-water inlet and outlet must not be reversed.

The pressure of the cooling water must not exceed 8 bars.

If the gear unit is being withdrawn from service for a longer period or if there is a danger of freezing, the cooling water must be drained off. Remove any remaining water with compressed air.

6. Assembly

Note: Observe the "Safety instructions" in section 3.

6.1 General

Note: Please also observe the Operating Instructions of the gear unit.

All preserved flange surfaces must be washed down with a solvent, e.g. petroleum ether.



Environmental protection requirements must be observed.

- If connection pipes are not supplied with the system, seamlessly drawn and bright normalised (NBK) pipes of ST 35.4 in accordance with DIN 2391 c (hydraulic tubing, quality grade C) must be used.
- The interfaces must be provided with the appropriate flanges or screw connections.
- For connection pipes we recommend using compensators to insulate against vibration and compensate for stretching.
- Pipe fastenings (plastic clips) must be used to install piping. The distance between clips must be less than 2 m / 78.7".
- Make sure the piping is not twisted.
- After installation the pipes must be flushed out. Welded pipes must be pickled.
- The motors and monitoring equipment must be connected up electrically in accordance with terminal diagrams, equipment lists and regulations. Check voltage and circuits.
- Before connecting the water oil-cooler remove the plugs from the water connection and flush the water oil-cooler well to remove any dirt.
- Install the cooling-water in- and outflow pipes. For the flow direction of the cooling water and the location of the connections please refer to the dimensioned drawing.
- Wire pressure monitor, temperature monitoring system and differential pressure monitor electrically.

6.2 General notes on add-on components

Note: For operation and maintenance of the components specified in the equipment list, observe the specified operating instructions.
For technical data, refer to the list of equipment.

6.3 Final installation work

After the gear unit has been installed with the oil supply system, check that all visible screw connections are correctly tightened and, if necessary, retighten.



Mount necessary safety equipment!

7. Start-up

Note: Observe the "Safety instructions" in section 3.

7.1 Oil filling

Note: Please also observe the Operating Instructions of the gear unit.

To remove preservative residues, which could cause the oil to foam, the oil supply system must be flushed out together with the gear unit before starting up.

Before starting up the gear unit/oil supply system must be filled with oil. After filling the filling holes must be correctly closed and sealed.

The oil must then be carefully drained out of the oil supply system, the monitoring equipment and the oil chambers in the gear unit, while it is warm. It may be re-used only as flushing oil. The flushing oil must be cleaned before re-use.



There is a danger of scalding from the hot oil emerging from the housing. Wear protective gloves.

Caution!

Remove any oil spillage immediately with an oil-binding agent.

Oil must be put into the oil supply system via the gear unit (see operating instructions for "Gear Unit"). Care must be taken that no dirt can get into the oil circuit.

Oil must be poured in until it is level with the mark on the oil level indicator, while the pump is not operating (see operating instructions for "Gear Unit"). The pump can then be started.

Caution!

Start oil supply system 1 minute before the gear unit. Never operate the gear unit without the oil supply system!

Before starting up the gear unit for the first time the oil supply system must be run for at least 15 minutes to fill all the oil chambers (see operating instructions for "Gear Unit"). Then shut down the oil supply system and, if necessary, correct the oil level).

All piping - particularly suction pipes (inadmissible air intake) - as well as all screw connections and flanges must be retightened. Leaks must be resealed.

7.2 Pump

Caution!

The low-pressure pumps are approved for one direction of rotation only. The direction of rotation of the motors must correspond to the direction of the arrow on the pump.

As regards the pump, the specific Operating Instructions must be observed.

7.3 Water oil-cooler

The necessary water connections must be manufactured by the customer/operator for the water oil-cooler.

If the oil supply system is shut down for a longer period or if there is a danger of freezing, the cooling water must be drained off.

As regards the water oil-cooler, the specific Operating Instructions of the manufacturer must be observed.

7.4 Start-up

Before starting up the oil supply system check whether these operating instructions and the operating instructions for the gear unit have been correctly adhered to.

Caution!

**In all cases oil must be put in before starting up.
The cooling water circuit must be checked before starting up!
Shut-off valves must be secured against unintentional closing.**

All impurities must be removed from the oil supply system before starting up and after repair and maintenance work. This applies particularly to water (e.g. rainwater and leakage from the water oil-cooler) to prevent an oil-water mixture.

All pumps, filters and coolers must be ventilated.



Pressure relief valve/safety valve pressure settings made by FLENDER at its works must not be altered, as they are not used to control the pressure and the flow rate. They serve only as a protection against overload.

7.5 Removal from service

To remove the oil supply system from service, it must be shut off.



Secure the oil supply system to prevent it from being started up unintentionally. Attach a warning notice to the start switch.

- With oil supply systems fitted with water oil-coolers, close the stop valves on the water inflow and outflow pipes. To prevent freezing, drain the water from the water oil-cooler.

7.5.1 Interior protection with preservative agent

Oil supply systems with forced lubrication should be run idle with preservative prior to any long-term storage.

Duration of protection	Preservative agent	Special measures
up to 6 months	Castrol Alpha SP 220 S	None
up to 24 months		Close connection pipes
For storage periods longer than 24 months the oil supply system must be re-preserved. For storage periods over 36 months FLENDER should be consulted.		

Table 7.1: Preservation procedure when using mineral oil or PAO-based synthetic oil

Duration of protection	Preservative agent	Special measures
up to 6 months	Special anti-corrosion oil TRIBOL 1390 1)	None
up to 36 months		Close connection pipes
For storage periods over 36 months FLENDER should be consulted.		

Table 7.2: Preservation procedure when using PG-based synthetic oil

- 1) Resistant to tropical conditions and sea water. Max. ambient temperature 50 °C

7.5.2 Interior preservation procedure

- Remove the oil supply system from service and drain off the oil
- Fill the oil supply system (if necessary, via the connected gear unit) with a sufficient quantity of preservative agent as indicated in Table 7.1 or 7.2
- Start the oil supply system and allow it to idle for a short time.
- Drain off the preservative agent into a suitable receptacle and dispose of the oil in accordance with the regulations



There is a risk of scalding from the hot preservative agent draining from the gear unit. Wear protective gloves to avoid scalding.

8. Operation

Note: Observe the "Safety instructions" in section 3.

Note: Please also observe the Operating Instructions of the gear unit.

8.1 Lubrication diagram

For the relevant lubrication diagram drawing number, refer to the list of equipment.

8.2 Control information

The part numbers (...) given in the following text have been taken from the enclosed list of equipment, assembly drawing and the lubrication diagram.

The following control information must be noted for the individual components:

Note: In addition to this control information, the specifications in the enclosed equipment list must always be observed.

Note: Only the control information of the part numbers shown in the list of equipment applies to the delivered oil supply system. For the specific switching points and values, refer to the list of equipment.

8.2.1 Pump (10)

When the pump is operating, the system pressure is limited by a pressure relief valve integrated into the pump.

Caution!

The factory adjustment of this valve may not be changed!

8.2.2 Filter (20)

The filter (20) is monitored visually by means of a differential pressure indicator and electrically by means of a differential pressure monitor.

8.2.3 Three-way cock (17)

A three-way cock is privoded downstream of the cooler for refilling purposes. The cock's position is to be adjusted in accordance with the desired function in each instance (see position symbol on the three-way cock and the oil flow in the lubrication diagram).

Caution!

During the filling process the pump must not be operating. After the filling process the cock must be set in operating position again.

8.2.4 Pressure gauge (45)

The oil pressure is indicated visually by means of a pressure gauge.

8.2.5 Pressure monitor (50)

The pressure in the oil supply system is monitored by means of pressure monitor.

8.2.6 Thermometer (60)

The oil temperature is indicated visually by means of a thermometer.

8.2.7 Resistance thermometer (65)

The temperature of the system is monitored by means of a resistance thermometer.

8.2.8 Temperature monitor (70)

The temperature of the system is monitored by means of a temperature sensor.

8.2.9 Cooling-water flow regulator (500)

The water circuit is controlled by means of a temperature-controlled cooling-water flow regulator, the sensor of which is screwed in downstream of the water oil-cooler.

8.2.10 General

After switching off the main drive the oil supply system must continue to run until the drive has come to a complete standstill.

8.3 Interlocking instructions

8.3.1 Gear unit enable

GEAR UNIT ENABLE takes place when all the following conditions are fulfilled:

Oil pressure > Switching point (50)

Oil temperature < Switching point (70) or < temperature value (65)

Filter differential pressure < Switching point (20)

Run-up time on the oil supply system at least 1 minutes.

8.3.2 Warning

WARNING is given when at least one of the following conditions is fulfilled:

Oil temperature > Switching point (70) or > temperature value (65)

Filter differential pressure > Switching point (20) after a period of 30 s

8.3.3 Gear unit stop

GEAR UNIT STOP takes place when at least one of the following conditions is fulfilled:

Oil pressure < Switching point (50)

Oil temperature > Switching point (70) or > temperature value (65)

If, when **GEAR UNIT STOP** occurs, the oil temperature is > switching point (70) or > temperature value (65), the pump must be set to remain on up to an oil temperature < switching point (70) or < temperature value (65).

8.4 Response to malfunctions



Irrespective of the following information, the local safety requirements will apply in all cases for operation of the oil supply system.

Monitoring during operation is essential to identify any malfunctions occurring (see Section 9, "Disturbances, reasons and remedy") and thus to implement preventive measures. The operating pressures and oil temperatures should be recorded regularly.

If irregularities at variance with the normal condition are noticed during operation, or if the operating data change, it is essential that the cause be identified immediately. If necessary, shut the system off. If the causes cannot be identified, even with the aid of the Troubleshooting List, inform FLENDER at once (see Section 11, "Stocking spare parts, service facility addresses").



We URGENTLY recommend that a lockable emergency switch be provided to ensure that the system is secured to prevent accidental switch-on during maintenance, repairs, or malfunctions. In addition, we would draw attention to the relevant accident prevention regulations on site!

For restart after malfunction, the information in Section 7, "Start-up" should be noted.

8.5 Shut-down

If the gear unit and oil supply system are shut down for longer periods, the following measures are necessary:

- a) Gear unit and oil supply system should remain filled with oil. Every 4 weeks gear unit and oil supply system must be run for 1 hour. The necessary prelubrication and lubrication times should be observed.
- b) If the measures listed under a) are not possible, the gear unit and the oil supply system (see section 7, "Start-up") must be preserved.
Please also observe the Operating Instructions of the gear unit.

Note: If the oil supply system is shut down for a longer period or if there is a danger of freezing, the cooling water must be drained off.

9. Faults, causes and remedy

Note: Observe the "Safety instructions" in section 3.

9.1 General information on faults and malfunctions

Note: Please also observe the Operating Instructions of the gear unit.

Note: Faults and malfunctions occurring during the guarantee period and requiring repair work on the oil supply system must be carried out only by the FLENDER Customer Service.
In the case of faults and malfunctions occurring after the guarantee period and whose cause cannot be precisely identified we advise our customers to contact our customer service.

Caution!

FLENDER will not be bound by the terms of the guarantee or otherwise be responsible in cases of improper use of the oil supply system, modifications carried out without FLENDER's agreement, or use of spare parts not supplied by FLENDER.



**When remedying faults and malfunctions, the oil supply system must always be taken out of service.
Secure the drive unit to prevent it from being started up unintentionally.
Attach a warning notice to the start switch.**

9.2 Possible faults

Malfunctions	Causes	Remedy
Oil temperature too high	<p>No cooling water Insufficient cooling water Cooling water too warm</p> <p>Water oil-cooler has air in it</p> <p>Water oil-cooler contaminated</p>	<p>Rectify cooling water supply Increase cooling water supply</p> <p>Ventilate the water oil-cooler</p> <p>Remove pipe assembly and clean water oil-cooler and pipe assembly or replace with new pipe assembly. See separate Operating Instructions (BA).</p>
Oil temperature too low	<p>Gear unit has not heated up.</p> <p>Too much cooling water Cooling water too cold</p>	<p>Wait</p> <p>Reduce cooling water supply</p>
Oil pressure too low	<p>Filter clogged</p> <p>Suction line clogged</p> <p>Pump is drawing in air</p> <p>Oil temperature too high</p> <p>Oil viscosity too low</p> <p>Pump defective, pump drive defective</p> <p>Pressure relief valve incorrectly set</p> <p>Pressure relief valve defective</p>	<p>Clean or replace filter element, or switch to clean filter and clean or replace filter element See separate Operating Instructions (BA).</p> <p>Clean suction pipe</p> <p>Check suction pipe and, if necessary, repair leaks.</p> <p>see there</p> <p>Check oil viscosity and, if necessary, put in correct oil.</p> <p>Repair or replace pump. See separate Operating Instructions (BA).</p> <p>Contact FLENDER.</p> <p>Repair or replace pressure relief valve. See separate Operating Instructions (BA).</p>
Oil pressure too high	<p>Gear unit has not yet heated up</p> <p>Oil pipes to and on gear unit blocked</p> <p>Oil viscosity too high</p> <p>Pressure relief valve incorrectly set</p> <p>Pressure relief valve defective</p>	<p>Wait</p> <p>Find and clean blocked pipe</p> <p>Check oil viscosity and, if necessary, put in correct oil.</p> <p>Contact FLENDER.</p> <p>Repair or replace pressure relief valve. See separate Operating Instructions (BA).</p>

FLENDER

Malfunctions	Causes	Remedy
Filter contaminated (unusual or increased filter residues)	Filter contaminated	Clean or replace filter
	Pipes dirty (Scale, welding residues)	Clean the pipes
	Oil contaminated	Change oil
	Abraded material from defective pump	Repair or replace pump See separate Operating Instructions (BA).
	Abraded material from gear unit	Check gear unit (bearings, teeth, alignment) and repair defects
Oil consumption too high	Leak in pipes, connections, valves or gear unit	Tighten screws. Reseal
	Shaft outlets on gear unit leaky	Replace sealing rings
	Water oil-cooler leaky	Replace sealing rings Seal or replace water oil-cooler. See separate Operating Instructions (BA).
	Filter leaky	Seal filter

Table 9.1: Faults, causes and remedies

10. Maintenance and repair

Note: Observe the "Safety instructions" in section 3.

Note: Please also observe the Operating Instructions of the gear unit.

10.1 Oils

For oil types and required oil change frequencies, refer to the operating instructions for the gear unit.

10.2 Pump

For the pump, observe our supplier's specific operating instructions.

10.3 Filter

For filters, observe our supplier's specific operating instructions.

10.4 Water oil-cooler

For water oil-coolers, observe our supplier's specific operating instructions.

10.5 Preservation

see Section 8, "Operation"

11. Spare parts, customer-service addresses

11.1 Stocking spare parts

By stocking the most important spare and wearing parts on site you can ensure that the oil supply system is ready for use at any time.

To order spare parts, refer to the list of equipment.

We guarantee only the original spare parts supplied by us.

Caution!

Please note that spare parts and accessories not supplied by us have not been tested or approved by us. The installation and/or use of such products may therefore impair essential characteristics of the oil supply system, thereby posing an active or passive risk to safety. FLENDER will assume no liability or guarantee for damage caused by spare parts and accessories not supplied by FLENDER.

Please note that certain components often have special production and supply specifications and that we supply you with spare parts which comply fully with the current state of technical development as well as current legislation.

When ordering spare parts, always state the following:

Material no.	Type / Size	Part no.	Quantity
--------------	-------------	----------	----------

11.2 Spare-part and customer-service addresses

When ordering spare parts or the services of our specialist engineers, apply first to FLENDER AG.

Adressen - Deutschland

A. FRIEDR. FLENDER AG	Alfred-Flender-Straße 77 46395 Bocholt	Postfach 1364 46393 Bocholt	Tel.: (0 28 71) 92 - 0 Fax: (0 28 71) 92 - 25 96	contact@flender.com www.flender.com
A. FRIEDR. FLENDER AG Kundenservice Center Nord	Alfred-Flender-Straße 77 46395 Bocholt	Postfach 1364 46393 Bocholt	Tel.: (0 28 71) 92 - 0 Fax: (0 28 71) 92 - 14 35	ksc.nord@flender.com www.flender.com
A. FRIEDR. FLENDER AG Kundenservice Center Süd	Bahnhofstraße 40 - 44 72072 Tübingen	Postfach 1709 72007 Tübingen	Tel.: (0 70 71) 7 07 - 0 Fax: (0 70 71) 7 07 - 3 40	ksc.sued@flender.com www.flender.com
A. FRIEDR. FLENDER AG Kundenservice Center Süd (Außenstelle München)	Liebigstraße 14	85757 Karlsfeld	Tel.: (0 81 31) 90 03 - 0 Fax: (0 81 31) 90 03 - 33	ksc.sued@flender.com www.flender.com
A. FRIEDR. FLENDER AG Kundenservice Center Ost / Osteuropa	Schlossallee 8	13156 Berlin	Tel.: (0 30) 91 42 50 58 Fax: (0 30) 47 48 79 30	ksc.ost@flender.com www.flender.com
A. FRIEDR. FLENDER AG Werk Friedrichsfeld	Am Industriepark 2	46562 Voerde	Tel.: (0 28 71) 92 - 0 Fax: (0 28 71) 92 - 25 96	contact@flender.com www.flender.com
A. FRIEDR. FLENDER AG Getriebewerk Penig	Thierbacher Straße 24 09322 Penig	Postfach 44/45 09320 Penig	Tel.: (03 73 81) 60 Fax: (03 73 81) 8 02 86	ute.tappert@flender.com www.flender.com
A. FRIEDR. FLENDER AG Kupplungswerk Mussum	Industriepark Bocholt Schlavenhorst 100	46395 Bocholt	Tel.: (0 28 71) 92 - 28 68 Fax: (0 28 71) 92 - 25 79	couplings@flender.com www.flender.com
A. FRIEDR. FLENDER AG FLENDER GUSS	Obere Hauptstraße 228 - 230	09228 Chemnitz/ Wittgensdorf	Tel.: (0 37 22) 64 - 0 Fax: (0 37 22) 94 - 1 38	flender.guss@flender- guss.com www.flender-guss.de
WINERGY AG	Am Industriepark 2 46562 Voerde	Postfach 201160 46553 Voerde	Tel.: (0 28 71) 9 24 Fax: (0 28 71) 92 - 24 87	info@winergy-ag.com www.winergy-ag.com
FLENDER TÜBINGEN GMBH	Bahnhofstraße 40 - 44 72072 Tübingen	Postfach 1709 72007 Tübingen	Tel.: (0 70 71) 7 07 - 0 Fax: (0 70 71) 7 07 - 4 00	sales-motox@flender- motox.com www.flender.com
LOHER GMBH	Hans-Loher-Straße 32 94099 Ruhstorf	Postfach 1164 94095 Ruhstorf	Tel.: (0 85 31) 3 90 Fax: (0 85 31) 3 94 37	info@loher.de www.loher.de
FLENDER SERVICE GMBH	Südstraße 111 44625 Herne	Postfach 101720 44607 Herne	Tel.: (0 23 23) 9 40 - 0 Fax: (0 23 23) 9 40 - 3 33	infos@flender- service.com www.flender-service.com
	24h Service Hotline		+49 (0) 17 22 81 01 00	

Addresses - International

(2004-11)

EUROPE					
AUSTRIA	Flender Ges.m.b.H.	Industriezentrum Nö-Süd Strasse 4, Objekt 14 Postfach 132	2355 Wiener Neudorf	Phone: +43 (0) 22 36 - 6 45 70 Fax: +43 (0) 22 36 - 6 45 70 10	office@flender.at www.flender.at
BELGIUM & LUXEMBOURG	N.V. Flender Belge S.A.	Cyriel Buyssestraat 130	1800 Vilvoorde	Phone: +32 (0) 2 - 2 53 10 30 Fax: +32 (0) 2 - 2 53 09 66	sales@flender.be
BULGARIA	Auto - Profi GmbH	Alabin Str. 52	1000 Sofia	Phone: +359 (0) 2 - 9 80 66 06 Fax: +359 (0) 2 - 9 80 33 01	flender@auto-profi.com
CROATIA / SLOVENIA BOSNIA- HERZEGOVINA	HUM - Naklada d.o.o.	Mandroviceva 3	10 000 Zagreb	Phone: +385 (0) 1 - 2 30 60 25 Fax: +385 (0) 1 - 2 30 60 24	flender@hi.htnet.hr
CZECH REPUBLIC	A. Friedr. Flender AG	Branch Office Hotel DUO, Teplicka 17	19 000 Praha 9	Phone: +420 2 - 83 88 23 00 Fax: +420 2 - 83 88 22 05	flender_pumprla@ hotelduo.cz
DENMARK	Flender Scandinavia A/S	Rugmarken 35 B	3520 Farum	Phone: +45 - 70 22 60 03 Fax: +45 - 44 99 16 62	kontakt@ flenderscandinavia.com www.flenderscandinavia.com
ESTHONIA / LATVIA LITHUANIA	Addinol Mineralöl Marketing OÜ	Suur-Sõjamäe 32	11 415 Tallinn (Esthonia)	Phone: +372 (0) 6 - 27 99 99 Fax: +372 (0) 6 - 27 99 90	flender@addinol.ee www.addinol.ee
FINLAND	Flender Oy	Ruusilantie 2 B	00 390 Helsinki	Phone: +358 (0) 9 - 4 77 84 10 Fax: +358 (0) 9 - 4 36 14 10	webmaster@flender.fi www.flender.fi
FRANCE	Flender S.a.r.l.	Head Office 3, rue Jean Monnet - B.P. 5	78 996 Elancourt Cedex	Phone: +33 (0) 1 - 30 66 39 00 Fax: +33 (0) 1 - 30 66 35 13	sales@flender.fr
	Flender S.a.r.l.	Sales Office Agence de Lyon Parc Inopolis, Route de Vourles	69 230 Saint Genis Laval	Phone: +33 (0) 4 - 72 83 95 20 Fax: +33 (0) 4 - 72 83 95 39	sales@flender.fr
FRANCE	Flender-Graffenstaden SA	1, rue du Vieux Moulin B.P.84	67 400 Illkirch - Graffenstaden 67 402 Illkirch - Graffenstaden	Phone: +33 (0) 3 - 88 67 60 00 Fax: +33 (0) 3 - 88 67 06 17	flencomm@flender-graff.com
GREECE	Flender Hellas Ltd.	2, Delfon str.	11 146 Athens	Phone: +30 210 - 2 91 72 80 Fax: +30 210 - 2 91 71 02	flender@otenet.gr
HUNGARY	Wentech Kft.	Bécsi Út 3-5	1023 Budapest	Phone: +36 (0) 1 - 3 45 07 90 Fax: +36 (0) 1 - 3 45 07 92	flender_bihari@hotmail.com jambor.laszlo@axelero.hu
ITALY	Flender Cigala S.p.A.	Parco Tecnologico Manzoni Palazzina G Viale delle industrie, 17	20 040 Caponago (MI)	Phone: +39 (0) 02 - 95 96 31 Fax: +39 (0) 02 - 95 74 39 30	info@flendercigala.it
THE NETHERLANDS	Flender Nederland B.V.	Lage Brink 5-7 Postbus 1073	7317 BD Apeldoorn 7301 BH Apeldoorn	Phone: +31 (0) 55 - 5 27 50 00 Fax: +31 (0) 55 - 5 21 80 11	sales@flender.nl www.flender.nl
THE NETHERLANDS	Bruinhof B.V.	Boterdiep 37 Postbus 9607	3077 AW Rotterdam 3007 AP Rotterdam	Phone: +31 (0) 10 - 4 97 08 08 Fax: +31 (0) 10 - 4 82 43 50	info@bruinhof.nl www.bruinhof.nl
NORWAY	Flender Scandinavia A/S	Rugmarken 35 B	3520 Farum	Phone: +45 - 70 22 60 03 Fax: +45 - 44 99 16 62	kontakt@ flenderscandinavia.com www.flenderscandinavia.com
POLAND	A. Friedr. Flender AG	Branch Office Przedstawicielstwo w Polsce ul. Wyzwolenia 27	43-190 Mikołów	Phone: +48 (0) 32 - 2 26 45 61 Fax: +48 (0) 32 - 2 26 45 62	flender@pro.onet.pl www.flender.pl
PORTUGAL	Rodamientos FEYC, S.A	R. Jaime Lopes Dias, 1668 CV	1750-124 Lissabon	Phone: +351 (0) 21 - 7 54 24 10 Fax: +351 (0) 21 - 7 54 24 19	info@rfportugal.com
ROMANIA	CN Industrial Group srl	B-dul Garii Obor nr. 8D Sector 2	021747 Bucuresti	Phone: +40 (0) 21 - 2 52 98 61 Fax: +40 (0) 21 - 2 52 98 62	office@flender.ro
RUSSIA	Flender OOO	Tjuschina 4-6	191 119 St. Petersburg	Phone: +7 (0) 8 12 - 3 20 90 34 Fax: +7 (0) 8 12 - 3 40 27 60	flendergus@mail.spbnit.ru
SLOVAKIA	A. Friedr. Flender AG	Branch Office Vajanského 49, P.O. Box 286	08 001 Presov	Phone: +421 (0) 51 - 7 70 32 67 Fax: +421 (0) 51 - 7 70 32 67	micenko.flender@nextra.sk
SPAIN	Flender Ibérica S.A.	Poligono Industrial San Marcos Calle Morse, 31 (Parcela D-15)	28 906 Getafe - Madrid	Phone: +34 (0) 91 - 6 83 61 86 Fax: +34 (0) 91 - 6 83 46 50	f-iberica@flender.es www.flender.es
SWEDEN	Flender Scandinavia	Åsenvägen 2	44 339 Lerum	Phone: +46 (0) 302 - 1 25 90 Fax: +46 (0) 302 - 1 25 56	kontakt@ flenderscandinavia.com www.flenderscandinavia.com
SWITZERLAND	Flender AG	Zeughausstr. 48	5600 Lenzburg	Phone: +41 (0) 62 - 8 85 76 00 Fax: +41 (0) 62 - 8 85 76 76	info@flender.ch www.flender.ch
TURKEY	Flender Güc Aktarma Sistemleri Sanayi ve Ticaret Ltd. Sti.	IMES Sanayi, Sitesi E Blok 502, Sokak No.22	81 260 Dudullu - Istanbul	Phone: +90 (0) 2 16 - 4 66 51 41 Fax: +90 (0) 2 16 - 3 64 59 13	cuzkan@flendertr.com www.flendertr.com
UKRAINE	DIV-Deutsche Industrievertretung	Prospect Pobedy 44	03 057 Kiev	Phone: +380 (0) 44 - 2 30 29 43 Fax: +380 (0) 44 - 2 30 29 30	flender@div.kiev.ua
UNITED KINGDOM & EIRE	Flender Power Transmission Ltd.	Thornbury Works, Leeds Road	Bradford West Yorkshire BD3 7EB	Phone: +44 (0) 12 74 - 65 77 00 Fax: +44 (0) 12 74 - 66 98 36	flenders@flender-power.co.uk www.flender-power.co.uk
SERBIA- MONTENEGRO ALBANIA MACEDONIA	G.P.Inzenjering d.o.o.	III Bulevar 54/19	11070 Novi Beograd	Phone: +381 (0) 11 - 60 44 73 Fax: +381 (0) 11 - 3 11 67 91	flender@eunet.yu

FLENDER

AFRICA

NORTH AFRICAN COUNTRIES	Flender S.a.r.l.	3, rue Jean Monnet - B.P.5	78996 Elancourt Cedex	Phone: +33 (0) 1 - 30 66 39 00 Fax: +33 (0) 1 - 30 66 35 13	sales@flender.fr
EGYPT	Sons of Farid Hassanen	81 Matbaa Ahlia Street	Boulac 11221, Cairo	Phone: +20 (0) 2 - 5 75 15 44 Fax: +20 (0) 2 - 5 75 17 02	hussein@sonfarid.com
SOUTH AFRICA	Flender Power Transmission (Pty.) Ltd.	Head Office Cnr. Furnace St & Quality Rd. P.O. Box 131	Isando 1600 Johannesburg	Phone: +27 (0) 11 - 5 71 20 00 Fax: +27 (0) 11 - 3 92 24 34	sales@flender.co.za www.flender.co.za
	Flender Power Transmission (Pty.) Ltd.	Sales Offices Unit 3 Marconi Park 9 Marconi Crescent, Montague Gardens, P.O.Box 37291	Chempet 7442 Cape Town	Phone: +27 (0) 21 - 5 51 50 03 Fax: +27 (0) 21 - 5 52 38 24	sales@flender.co.za
	Flender Power Transmission (Pty.) Ltd.	Unit 3 Goshawk Park Falcon Industrial Estate P.O. Box 1608	New Germany 3620 Durban	Phone: +27 (0) 31 - 7 05 38 92 Fax: +27 (0) 31 - 7 05 38 72	sales@flender.co.za
	Flender Power Transmission (Pty.) Ltd.	9 Industrial Crescent, Ext. 25 P.O. Box 17609	Witbank 1035	Phone: +27 (0) 13 - 6 92 34 38 Fax: +27 (0) 13 - 6 92 34 52	sales@flender.co.za
Flender Power Transmission (Pty.) Ltd.	Unit 14 King Fisher Park, Alton Cnr. Ceramic Curve & Alumina Allee, P.O.Box 101995	Meerensee 3901 Richards Bay	Phone: +27 (0) 35 - 7 51 15 63 Fax: +27 (0) 35 - 7 51 15 64	sales@flender.co.za	

AMERICA

ARGENTINA	Chilicote S.A.	Avda. Julio A. Roca 546	C 1067 ABN Buenos Aires	Phone: +54 (0) 11 - 43 31 66 10 Fax: +54 (0) 11 - 43 31 42 78	chilicote@chilicote.com.ar
BRASIL	Flender Brasil Ltda.	Head Office Rua Quatorze, 60 Cidade Industrial	32210 - 660 Contagem - MG	Phone: +55 (0) 31 - 33 69 20 00 Fax: +55 (0) 31 - 33 31 18 93	vendas@flenderbrasil.com
	Flender Brasil Ltda.	Sales Offices Rua James Watt, 142 conjunto 142 - Brooklin Novo	04576 - 050 São Paulo - SP	Phone: +55 (0) 11 - 55 05 99 33 Fax: +55 (0) 11 - 55 05 30 10	flesao@uol.com.br
	Flender Brasil Ltda.	Av. Presidente Vargas, 2001 Edificio New Century - 11o. andar - sala 118 Bairro Alto da Boa Vista	14020 - 260 Ribeirão preto - SP	Phone: +55 (0) 16 - 39 11 90 60 Fax: +55 (0) 16 - 39 11 90 09	marcos.stevanato@wba.brasil.com
	Flender Brasil Ltda.	Rua da Mitra - quadre 30 - lote16 Edifício Cristal - sala 207 Bairro Renascença	65075 - 770 São Luis - MA	Phone: +55 (0) 98 - 2 35 84 92 Fax: +55 (0) 98 - 2 35 84 93	flenderslz@uol.com.br
Flender Brasil Ltda.	Rua Padre Anchieta, 1691 conjunto 1110 - Bairro Bigorriho	80730 - 000 Curitiba - PR	Phone: +55 (0) 41 - 3 36 28 49 Fax: +55 (0) 41 - 3 36 28 49	flender.curitiba@uol.com.br	
CANADA	Flender Power Transmission Inc.	215 Shields Court, Units 4-6	Markham Ontario L3R 8V2	Phone: +1 (0) 9 05 - 3 05 10 21 Fax: +1 (0) 9 05 - 3 05 10 23	info@flenderpti.com www.flender.ca
CHILE / ARGENTINA BOLIVIA / ECUADOR PARAGUAY URUGUAY	Flender Cono Sur Ltda.	Avda. Galvarino Gallardo 1534	Providencia, Santiago	Phone: +56 (0) 2 - 2 35 32 49 Fax: +56 (0) 2 - 2 64 20 25	flender@flender.cl www.flender.cl
COLOMBIA	A.G.P. Representaciones Ltda.	Flender Liaison Office Colombia Av Boyaca No. 23 A 50 Bodega UA 7 - 1	Bogotá	Phone: +57 (0) 1 - 5 70 63 53 Fax: +57 (0) 1 - 5 70 73 35	aguerrero@agp.com.co www.agp.com.co
MEXICO	Flender de Mexico S.A. de C.V.	Head Office 17, Pte, 713 Centro	72000 Puebla	Phone: +52 (0) 2 22 - 2 37 19 00 Fax: +52 (0) 2 22 - 2 37 11 33	szugasti@flendermexico.com www.flendermexico.com
	Flender de Mexico S.A. de C.V.	Sales Offices Lago Nargis No.38 Col. Granada	11520 Mexico, D.F.	Phone: +52 (0) 55 - 52 54 30 37 Fax: +52 (0) 55 - 55 31 69 39	info@flendermexico.com
	Flender de Mexico S.A. de C.V.	Ave. San Pedro No. 231-5 Col. Miravalle	64660 Monterrey, N.L.	Phone: +52 (0) 81 - 83 63 82 82 Fax: +52 (0) 81 - 83 63 82 83	info@flendermexico.com
PERU	Potencia Industrial E.I.R.L.	Calle Gonzales Olaechea 110-URB, La Aurora	Miraflores, Lima	Phone: +51 (0) 1 - 2 42 84 68 Fax: +51 (0) 1 - 2 42 08 62	cesarzam@potenciaindustrial.com.pe www.potenciaindustrial.com.pe
USA	Flender Corporation	950 Tollgate Road P.O. Box 1449	Elgin, IL. 60123	Phone: +1 (0) 8 47 - 9 31 19 90 Fax: +1 (0) 8 47 - 9 31 07 11	flender@flenderusa.com www.flenderusa.com
	Flender Corporation	Service Centers West 4234 Foster Ave.	Bakersfield, CA. 93308	Phone: +1 (0) 6 61 - 3 25 44 78 Fax: +1 (0) 6 61 - 3 25 44 70	flender1@lightspeed.net
VENEZUELA	F. H. Transmisiones S.A.	Calle Johan Schafer o Segunda Calle, Municipio Sucre	Petare, Caracas	Phone: +58 (0) 2 12 - 21 52 61 Fax: +58 (0) 2 12 - 21 18 38	fhtransm@telcel.net.ve www.fhtransmisiones.com

FLENDER

ASIA

BANGLADESH SRI LANKA	Flender Limited	No.2 St. George's Gate Road 5 th Floor, Hastings	Kolkata - 700 022	Phone: +91 (0) 33 - 2 23 05 45 Fax: +91 (0) 33 - 2 23 18 57	flender@flenderindia.com
PEOPLE'S REPUBLIC OF CHINA	Flender Power Trans- mission (Tianjin) Co., Ltd.	Head Office ShuangHu Rd. - Shuangchen Rd. West, Beichen Economic Development Area (BEDA)	Tianjin 300400	Phone: +86 (0) 22 - 26 97 20 63 Fax: +86 (0) 22 - 26 97 20 61	flender@flendertj.com www.flendertj.com
	Flender Power Trans- mission (Tianjin) Co., Ltd.	Sales Offices C-414, Lufthansa Center 50 Liangmaqiao Rd. Chaoyang District	Beijing 100016	Phone: +86 (0) 10 - 64 62 21 51 Fax: +86 (0) 10 - 64 62 21 43	beijing@flenderprc.com.cn
	Flender Power Trans- mission (Tianjin) Co., Ltd.	1101 - 1102 Harbour Ring Plaza 18 Xizang Zhong Rd.	Shanghai 200001	Phone: +86 (0) 21 - 53 85 31 48 Fax: +86 (0) 21 - 53 85 31 46	shanghai@ flenderprc.com.cn
	Flender Power Trans- mission (Tianjin) Co., Ltd.	Rm.1503, Jianyin Building 709 Jiانشهداواو, Hankou	Wuhan 430015	Phone: +86 (0) 27 - 85 48 67 15 Fax: +86 (0) 27 - 85 48 68 36	wuhan@flenderprc.com.cn
	Flender Power Trans- mission (Tianjin) Co., Ltd.	Rm.2802, Guangzhou International Electronics Tower 403 Huanshi Rd. East	Guangzhou 510095	Phone: +86 (0) 20 - 87 32 60 42 Fax: +86 (0) 20 - 87 32 60 45	guangzhou@ flenderprc.com.cn
	Flender Power Trans- mission (Tianjin) Co., Ltd.	G-6 / F Guoxin Mansion 77 Xiyu Street	Chengdu 610015	Phone: +86 (0) 28 - 86 19 83 72 Fax: +86 (0) 28 - 86 19 88 10	chengdu@flenderprc.com.cn
	Flender Power Trans- mission (Tianjin) Co., Ltd.	Rm.3-705, Tower D City Plaza Shenyang 206 Nanjing Street (N) Heping District	Shenyang 110001	Phone: +86 (0) 24 - 23 34 20 48 Fax: +86 (0) 24 - 23 34 20 46	shenyang@flenderprc.com.cn
	Flender Power Trans- mission (Tianjin) Co., Ltd.	Rm.302, Shanzi Zhong Da International Mansion 30 Southern Rd.	Xi'an 710002	Phone: +86 (0) 29 - 87 20 32 68 Fax: +86 (0) 29 - 87 20 32 04	xian@flenderprc.com.cn
	Flender Power Trans- mission (Tianjin) Co., Ltd.	Rm.23E, Xinhua Plaza, No.6 Renmin East Rd.	Kunming 650051	Phone: +86 (0) 871 - 3 12 43 68 Fax: +86 (0) 871 - 3 12 45 66	kunming@flenderprc.com.cn
	Flender Power Trans- mission (Tianjin) Co., Ltd.	Rm.1007, Building A, Golden Center, Jincheng International Plaza, No.68 Jingsan Rd.	Zhengzhou 450008	Phone: +86 (0) 371 - 5 38 80 85 Fax: +86 (0) 371 - 5 38 80 89	zhengzhou@ flenderprc.com.cn
	Flender Power Trans- mission (Tianjin) Co., Ltd.	Rm.908 (east), No.188 Guangzhou Rd.	Nanjing 210024	Phone: +86 (0) 25 - 83 24 25 50 Fax: +86 (0) 25 - 83 24 48 20	nanjing@flenderprc.com.cn
	Flender Power Trans- mission (Tianjin) Co., Ltd.	Rm.1408, Pearl River International Building No.99 Xinkai Rd. Xigang District	Dalian 116011	Phone: +86 (0) 411 - 83 77 93 55 Fax: +86 (0) 411 - 83 77 92 19	dalian@flenderprc.com.cn
	Flender Power Trans- mission (Tianjin) Co., Ltd.	Rm.1401, Tianlin Building Hunan Gold Source Hotel No.279, Second Block Furong Rd.	Changsha 410007	Phone: +86 (0) 731 - 5 16 73 09 Fax: +86 (0) 731 - 5 16 47 46	changsha@ flenderprc.com.cn
INDIA	Flender Limited	Head Office No.2 St. George's Gate Road 5 th Floor	Hastings Kolkata - 700 022	Phone: +91 (0) 33 - 2 23 05 45 Fax: +91 (0) 33 - 2 23 18 57	flender@flenderindia.com
	Flender Limited	Industrial Growth Centre Rakhajungle	Nimpura Kharagpur - 721 302	Phone: +91 (0) 3222 - 23 33 07 Fax: +91 (0) 3222 - 23 33 64	works@flenderindia.com
	Flender Limited	Eastern Regional Sales Office No.2 St. George's Gate Road 5 th Floor	Hastings Kolkata - 700 022	Phone: +91 (0) 33 - 22 23 05 45 Fax: +91 (0) 33 - 22 23 08 30	ero@flenderindia.com
	Flender Limited	Western Regional Sales Office Plot No.23, Sector 19 - C	Vashi Navi Mumbai - 400 705	Phone: +91 (0) 22 - 27 65 72 27 Fax: +91 (0) 22 - 27 65 72 28	wro@flenderindia.com
	Flender Limited	Southern Regional Sales Office 41 Nelson Manickam Road	Aminjikarai Chennai - 600 029	Phone: +91 (0) 44 - 23 74 39 21 Fax: +91 (0) 44 - 23 74 39 19	sro@flenderindia.com
	Flender Limited	Northern Regional Sales Office 209-A, Masjid Moth, 2nd Floor (Behind South Extension II)	New Delhi - 110 049	Phone: +91 (0) 11 - 26 25 02 21 Fax: +91 (0) 11 - 26 25 63 72	nro@flenderindia.com
INDONESIA	Flender Singapore Pte. Ltd.	Representative Office 6-01 Wisma Presisi Jl. Taman Aries Blok A1 No.1	Jakarta Barat 11620	Phone: +62 (0) 21 - 58 90 20 15 Fax: +62 (0) 21 - 58 90 20 19	bobwall@cbn.net.id
IRAN	Cimaghand Co. Ltd.	P.O. Box 15745-493 No.13, 16 th East Street Beyhaghi Ave., Argentina Sq.	Tehran 15156	Phone: +98 (0) 21 - 8 73 02 14 Fax: +98 (0) 21 - 8 73 39 70	info@cimaghand.com
ISRAEL	Greenshpon Engineering Works Ltd.	Bar-Lev Industrial Park	Misgav 20179	Phone: +972 (0) 4 - 9 91 31 81 Fax: +972 (0) 4 - 9 91 34 77	sales@greenshpon.com www.greenshpon.com
JAPAN	Flender Japan Co., Ltd.	WBG Marive East 21F Nakase 2-6 Mihama-ku, Chiba-shi	Chiba 261-7121	Phone: +81 (0) 43 - 2 13 39 30 Fax: +81 (0) 43 - 2 13 39 55	contact@flender-japan.com
KAZAKHSTAN	KazGate GmbH	Abay ave 143	480009 Almaty	Phone: +7 (0) - 32 72 - 74 09 71 Fax: +7 (0) - 32 72 - 42 94 10	flender@kazgate.de
KOREA	Flender Ltd.	7 th Fl. Dorim Bldg. 1823 Bangbae-Dong Secho-Ku	Seoul 137-060	Phone: +82 (0) 2 - 34 78 63 37 Fax: +82 (0) 2 - 34 78 63 45	sales@flender-korea.com www.flender-korea.com
KUWAIT	South Gulf Company	Al-Showaikh Ind. Area P.O. Box 26229	Safat 13123	Phone: +965 (0) - 4 82 97 15 Fax: +965 (0) - 4 82 97 20	adelameen@awalnet.net.sa
LEBANON	Gabriel Acar & Fils s.a.r.l.	Dahr-el-Jamal Zone Industrielle, Sin-el-Fil B.P. 80 484	Beyrouth	Phone: +961 (0) 1 - 49 82 72 Fax: +961 (0) 1 - 49 49 71	gacar@beirut.com
MALAYSIA	Flender Singapore Pte. Ltd.	Representative Office 37 A-2, Jalan PJU 1/39 Dataran Prima	47301 Petaling Jaya Selangor Darul Ehsan	Phone: +60 (0) 3 - 78 80 42 63 Fax: +60 (0) 3 - 78 80 42 73	flender@tm.net.my
PAKISTAN	A. Friedr. Flender AG	Postfach 1364	46393 Bocholt	Phone: +49 (0) 28 71 - 92 22 59 Fax: +49 (0) 28 71 - 92 15 16	ludger.wittag@flender.com

FLENDER

PHILIPPINES	Flender Singapore Pte. Ltd.	Representative Office 28/F, Unit 2814, The Enterprise Centre, 6766 Ayala Avenue corner, Paeso de Roxas	Makati City	Phone: +63 (0) 2 - 8 49 39 93 Fax: +63 (0) 2 - 8 49 39 17	junt@flender.com.ph
BAHRAIN / IRAQ LYBIA / JORDAN OMAN / QATAR U.A.E. / YEMEN	Flender Güc Aktarma Sistemleri Sanayi ve Ticaret Ltd. Sti.	Middle East Sales Office IMES Sanayi Sitesi E Blok 502, Sokak No. 22	81 260 Dudullu - Istanbul	Phone: +90 (0) 2 16 - 4 99 66 23 Fax: +90 (0) 2 16 - 3 64 59 13	meso@flendertr.com
SAUDI ARABIA	South Gulf Sands Est.	Bandaria Area, Dohan Bldg. Flat 3/1, P.O. Box 32150	Al-Khobar 31952	Phone: +966 (0) 3 - 8 87 53 32 Fax: +966 (0) 3 - 8 87 53 31	adelameen@awalnet.net.sa
SINGAPORE	Flender Singapore Pte. Ltd.	13 A, Tech Park Crescent	Singapore 637843	Phone: +65 (0) - 68 97 94 66 Fax: +65 (0) - 68 97 94 11	flender@singnet.com.sg www.flender.com.sg
SYRIA	Misrabi Co & Trading	Mezzeh Autostrade Transportation Building 4/A, 5 th Floor P.O. Box 12450	Damascus	Phone: +963 (0) 11 - 6 11 67 94 Fax: +963 (0) 11 - 6 11 09 08	ismael.misrabi@gmx.net
TAIWAN	A. Friedr. Flender AG	Taiwan Branch Company 1F, No.5, Lane 240 Nan Yang Street, Hsichih	Taipei Hsien 221	Phone: +886 (0) 2 - 26 93 24 41 Fax: +886 (0) 2 - 26 94 36 11	flender_tw@flender.com.tw
THAILAND	Flender Singapore Pte. Ltd.	Representative Office Talay-Thong Tower, 53 Moo 9 10 th Floor Room 1001 Sukhumvit Rd., T. Tungskula	A. Sriracha Chonburi 20230	Phone: +66 (0) 38 - 49 51 66 - 8 Fax: +66 (0) 38 - 49 51 69	contact@flender.th.com
VIETNAM	Flender Singapore Pte. Ltd.	Representative Office Suite 22, 16F Saigon Tower 29 Le Duan Street, District 1	Ho Chi Minh City	Phone: +84 (0) 8 - 8 23 62 97 Fax: +84 (0) 8 - 8 23 62 88	flender_vn@flender.com.vn
A U S T R A L I A					
	Flender (Australia) Pty. Ltd.	Head Office 9 Nello Place, P.O. Box 6047 Wetherill Park	N.S.W. 2164, Sydney	Phone: +61 (0) 2 - 97 56 23 22 Fax: +61 (0) 2 - 97 56 48 92	sales@flender.com.au www.flender.com.au
	Flender (Australia) Pty. Ltd.	Sales Offices Suite 3, 261 Centre Rd. Bentleigh	VIC 3204, Melbourne	Phone: +61 (0) 3 - 95 57 08 11 Fax: +61 (0) 3 - 95 57 08 22	sales@flender.com.au
	Flender (Australia) Pty. Ltd.	Suite 5, 1407 Logan Rd. Mt. Gravatt	QLD 4122, Brisbane	Phone: +61 (0) 7 - 34 22 23 89 Fax: +61 (0) 7 - 34 22 24 03	sales@flender.com.au
	Flender (Australia) Pty. Ltd.	Suite 2 403 Great Eastern Highway	W.A. 6104 Redcliffe - Perth	Phone: +61 (0) 8 - 94 77 41 66 Fax: +61 (0) 8 - 94 77 65 11	sales@flender.com.au
NEW ZEALAND	Flender (Australia) Pty. Ltd.	9 Nello Place, P.O. Box 6047 Wetherill Park	N.S.W. 2164, Sydney	Phone: +61 (0) 2 - 97 56 23 22 Fax: +61 (0) 2 - 97 56 48 92	sales@flender.com.au

12. Declaration by the manufacturer

Declaration by the manufacturer

in accordance with EC Engineering Guideline 98/37/EC, Appendix II B

We hereby declare that the

Oil supply systems of type **OWGX**

described in these Operating Instructions are intended for incorporation in a machine, and that it is prohibited to put them into service before verifying that the machine into which they are incorporated complies with the EC Guidelines (original edition 98/37/EC including any subsequent amendments thereto).

This Manufacturer's Declaration takes into account all the unified standards (inasmuch as they apply to our products) published by the European Commission in the Official Journal of the European Community.

Bocholt, 2004-10-29



Signature (Director TFE Engineering)