

# Operating Instructions

## BA 9751 EN 10.07

Oil supply systems of type **OLGE**

in design in accordance with Directive 94/9/EC

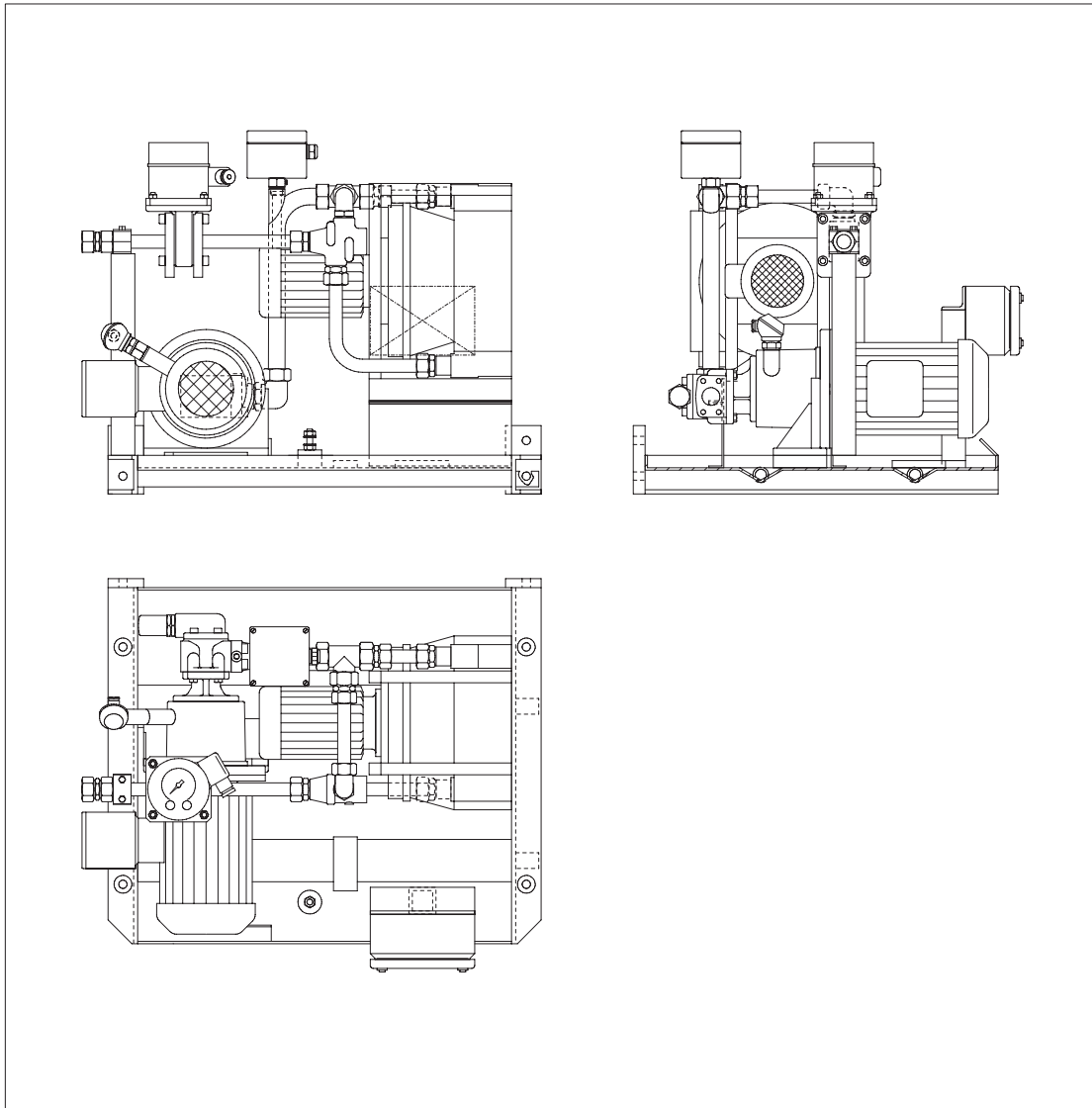

# FLENDER

## Contents

<b>1.</b>	<b>Technical data</b>	<b>4</b>
1.1	General technical data	4
1.2	Marking of the oil-supply system in design in accordance with Directive 94/9/EC	5
1.3	Oil viscosity / oil type	5
1.4	Ambient temperature	5
<b>2.</b>	<b>General notes</b>	<b>6</b>
2.1	Introduction	6
2.2	Copyright	6
<b>3.</b>	<b>Safety notes</b>	<b>6</b>
3.1	Proper use	6
3.2	Obligations of the user	7
3.3	Environmental protection	8
3.4	Special dangers	8
3.5	Warnings and symbols used in these Operating Instructions	8
<b>4.</b>	<b>Handling and storage</b>	<b>8</b>
4.1	Scope of supply	8
4.2	Handling	9
4.3	Storage of the oil supply system	10
4.4	Standard corrosion protection	10
<b>5.</b>	<b>Technical description</b>	<b>11</b>
5.1	General	11
5.2	Marking the oil supply system for explosion protection	11
5.3	Service conditions	11
<b>6.</b>	<b>Mounting</b>	<b>12</b>
6.1	General	12
6.2	Check before start-up	12
6.3	General notes on add-on components	12
6.4	Final installation work	13
<b>7.</b>	<b>Start-up</b>	<b>13</b>
7.1	Oil viscosity / oil type	13
7.2	Oil filling	13
7.3	Pump	14
7.4	Air oil-cooler	14
7.5	General notes on add-on components	14
7.6	Start-up	14
7.7	Removal from service	14
7.7.1	Interior protection with preservative agent	15
7.7.2	Interior preservation procedure	15

<b>8.</b>	<b>Operation</b>	<b>15</b>
8.1	Lubrication diagram	15
8.2	Oil viscosity / oil type	15
8.3	Control information	16
8.3.1	Pump (10)	16
8.3.2	Temperature monitor (17)	16
8.3.3	Filter (20)	16
8.3.4	Temperature-control valve (32)	16
8.3.5	Pressure gauge (45)	16
8.3.6	Pressure monitor (50, 55)	16
8.3.7	Thermometer (60)	16
8.3.8	Temperature monitor (70)	16
8.3.9	Temperature monitor (75)	16
8.3.10	Volume flow meter (80)	16
8.3.11	General	16
8.4	Interlocking specifications when using as a pressure lubrication system	17
8.4.1	Fan motor	17
8.4.2	Pump enable	17
8.4.3	Gear unit enable	17
8.4.4	Warning	17
8.4.5	Gear unit stop	17
8.5	Response to malfunctions	18
8.6	Shut-down	18
<b>9.</b>	<b>Faults, causes and remedy</b>	<b>18</b>
9.1	General information on faults and malfunctions	18
9.2	Possible faults	19
9.2.1	Possible faults when installing the oil supply system	20
9.2.2	Possible faults in maintenance	20
<b>10.</b>	<b>Maintenance and repair</b>	<b>21</b>
10.1	Oil viscosity / oil type	21
10.2	General notes on add-on components	21
10.3	Preservation	21
10.4	Cleaning	21
<b>11.</b>	<b>Spare parts, customer-service addresses</b>	<b>21</b>
11.1	Stocking spare parts	21
11.2	Spare parts and customer service addresses	21
<b>12.</b>	<b>Declaration by the manufacturer / Declaration of Conformity</b>	<b>26</b>

## 1. Technical data

### 1.1 General technical data

The most important technical data on the oil supply system are shown on the rating plate. These data and the contractual agreements between FLENDER and the customer for the oil supply system determine the limits of its correct use.

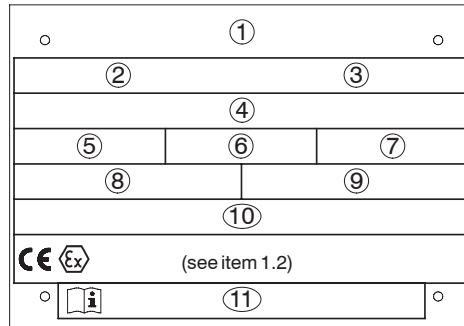







- ① Company logo and production location
- ② Material No.
- ③ Total weight
- ④ Production order no. / Year of construction of the oil supply system
- ⑤ Type
- ⑥ Size
- ⑦ Variant
- ⑧  $p_{Oil\ max.}$  = max. permissible oil operating overpressure
- ⑨  $t_{min.}$  = minimum starting temperature
- ⑩  $t_{u\ max.}$  ... °C / ... °F = max. permiss. ambient temperature
- ⑪ Operating Instructions number

**Note:** These Operating Instructions (BA) generally include a list of equipment including the drawings to the oil supply system and the operating instructions for the accessory components.

For further technical data, refer to the list of equipment and the drawings.

## 1.2 Marking of the oil-supply system in design in accordance with Directive 94/9/EC

Equipment group	Equipment category <sup>1)</sup>	"Ex" atmosphere	Explosion group <sup>2)</sup>	Temperature class <sup>3)</sup>	Identification marking <sup>5)</sup>
II	3	Gas (G)	IIA, IIB, IIC	T3, T4	  II 2 G IIA T4 bc T <sub>a</sub> .. <sup>4)</sup>
		Gas (G) and dust (D)	IIA, IIB, IIC	T3, T4	  II 2 G IIA T4 D 120 °C bc T <sub>a</sub> .. <sup>4)</sup>
		Dust (D)			  II 2 D 120 °C bc T <sub>a</sub> .. <sup>4)</sup>

- 1) Always only one equipment category can be indicated.
- 2) The explosion groups related to the gaseous atmosphere (G). Always only one explosion group can be indicated.
- 3) Always only one temperature class can be indicated.
- 4)  $T_{a \text{ min.}} \leq T_a \leq T_{a \text{ max.}}$  = permissible ambient temperature range in °C:  
 $T_{a \text{ min.}}$  = minimum permissible ambient temperature  
 $T_{a \text{ max.}}$  = maximum permissible ambient temperature  
 $T_a$  = symbol for ambient temperature in °C
- 5) The indications relating to equipment category, explosion group and temperature class are to be understood as an example.

**Note:** With oil-supply systems without electrical explosion hazard monitoring device (such as temperature, oil level) no ignition protection "b" is available.



**The rating plate on the oil-supply system indicates the marking for the applicable case of application.**

### 1.3 Oil viscosity / oil type

For the oil viscosity and oil type, refer to the operating instructions or the gear unit rating plate.

The oil supply systems are designed for oil viscosities < 5 000 cSt at minimum starting temperature (see rating plate ⑨).

### 1.4 Ambient temperature

The specifications of Directive 94/9/EC apply to the ambient temperature range of from – 20 °C to + 40 °C. By adopting various suitable measures the oil supply system may be used at ambient temperatures of up to + 60 °C. However, this must always be approved by FLENDER.

In individual cases the permissible ambient temperature range specified on the rating plate always applies.

## 2. General notes

### 2.1 Introduction

These Operating Instructions (BA) are an integral part of the delivery of the oil supply system and must be kept in its vicinity for reference at all times.

**Note:** The operating instructions (BA) for the gear unit must be observed.

**Caution!**

**All persons involved in the installation, operation, maintenance and repair of the oil supply system must have read and understood these Operating Instructions and must comply with them at all times. We accept no responsibility for damage or disruption caused by disregard of these Instructions.**

The "FLENDER oil supply system" dealt with in these Operating Instructions (BA) has been developed for use as an oil supply system of gear units. Possible applications for oil supply system of this series are the chemical, rubber, food plastics and other industries.

The oil supply system is designed only for the application described in section 1, "Technical data" and the List of Equipment.

The oil supply system described in these Instructions reflects the state of technical development at the time these Instructions (BA) went to print.

In the interest of technical progress we reserve the right to make changes to the individual assemblies and accessories which we regard as necessary to preserve their essential characteristics and improve their efficiency and safety.

### 2.2 Copyright

The copyright to these Operating Instructions (BA) is held by **FLENDER AG**.

These Operating Instructions (BA) must not be wholly or partly reproduced for competitive purposes, used in any unauthorised way or made available to third parties without our agreement.

Technical enquiries should be addressed to the following works

A. FRIEDR. FLENDER AG  
D-46393 Bocholt

Tel.: 02871/92-0  
Fax: 02871/92-2596

Internet: [www.flender.com](http://www.flender.com)

or to one of our customer-service addresses. A list of our customer-service addresses is given in section 11, "Spare parts, customer-service addresses".

## 3. Safety notes

**Note:** The operating instructions (BA) for the gear unit must be observed.

### 3.1 Proper use

- The oil supply system has been manufactured in accordance with the state of the art and is delivered in a condition for safe and reliable use. It complies with the requirements in Directive 94/9/EC.
- The oil supply system must be used and operated strictly in accordance with the conditions laid down in the contract governing performance and supply agreed by FLENDER and the customer.



**Any changes on the part of the user are not permitted. This applies equally to safety features designed to prevent accidental contact.**

## 3.2 Obligations of the user

- The operator must ensure that all persons involved in installation, operation, maintenance and repair have read and understood these Operating Instructions (BA) and comply with them at all times in order to:
    - avoid injury or damage,
    - ensure the safety and reliability of the oil supply system,
- and
- avoid disruptions and environmental damage through incorrect use.
  - During transport, assembly, installation, dismantling, operation and maintenance of the unit, the relevant safety and environmental regulations must be complied with at all times.
  - The oil supply system must be operated, maintained or repaired only by authorised, duly trained and qualified personnel.
  - The gear unit must not be cleaned using high-pressure cleaning equipment.
  - All work must be carried out with great care and with due regard to safety.
  - Unauthorized access to the oil supply system not permissible.
  - All work on the oil supply system must be carried out only when it is at a standstill. The drive unit must be secured against being switched on accidentally (e.g. by locking the key switch or removing the fuses from the power supply). A notice should be attached to the ON switch stating clearly that work on the oil supply system is in progress.
  - If any changes are noticed during operation of the oil supply system (e.g. increased operating temperature or unusual noises), the drive assembly must be switched off immediately.



**The control instructions in section 8 must always be observed.**

**All add-on parts must satisfy the requirements in Directive 94/9/EC.**

**Simple electrical means (such as monitoring devices, switches, PT100 resistance) without identification in accordance with Directive 94/9/EC are to be connected intrinsically safely by suitable isolation amplifiers.**

**The oil supply system must be protected against falling objects.**

**If the oil supply system is intended for mounting on plant or equipment, the manufacturer of such plant or equipment must ensure that the contents of the present Operating Instructions are incorporated in his own instructions.**

- Notices attached to the oil supply system, e.g. rating plate, direction arrows etc. must always be observed. They must be kept free from dirt and paint at all times. Missing plates must be replaced.
- Screws which have been damaged during assembly or disassembly work must be replaced with new ones of the same strength class and type.
- All spare parts must be obtained from FLENDER.

## 3.3 Environmental protection

- When changing oil, the used oil must be collected in suitable containers. Any spillage of oil must be removed immediately.
- Preservative agent should be stored separately from used oil.
- Used oil, preservative agent, oil-binding agents and oil-soaked cloths must be disposed of in accordance with environmental legislation.

## 3.4 Special dangers



**The oil supply system complies with the requirements in Directive 94/9/EC.**



**When carrying out assembly and disassembly work, ensure that no explosive gas mixtures are present.**

- Depending on operating conditions, the surface of the oil supply system may heat up considerably.  
**Danger of burns!**
- When changing oil, take care to prevent scalding by hot oil.

## 3.5 Warnings and symbols used in these Operating Instructions



This symbol indicates safety measures which must be observed with regard to **explosion protection**.



This symbol indicates safety measures which must be observed to avoid **personal injury**.

**Caution!**

This symbol refers to safety measures which must be observed to avoid **damage to the oil supply system and gear unit**.

**Note:** This symbol indicates general **operating instructions** which are of particular importance.

## 4. Handling and storage

Observe the "Safety instructions" in section 3.

**Note:** The Operating Instructions (BA) for the gear unit must be observed.

### 4.1 Scope of supply

The products supplied are listed in the despatch papers. Check immediately on receipt to ensure that all the products listed have actually been delivered. Parts damaged during transport or missing parts must be reported in writing immediately to FLENDER AG.



**If damage has occurred, the oil supply system must not be put into operation.**



## 4.2 Handling



**When handling FLENDER products, use only lifting and handling equipment of sufficient load-bearing capacity!**

The oil-supply system is delivered in the fully assembled condition. Additional items are delivered separately packaged, of applicable. Depending upon the individual application, they can also be assembled to the gear unit and delivered with it as an assembled unit.

Different forms of packaging may be used depending on the size of the oil supply system / assembled unit and method of transport. Unless otherwise agreed, the packaging complies with the **HPE Packaging Guidelines**.

The symbols marked on the packaging must be observed at all times. These have the following meanings:

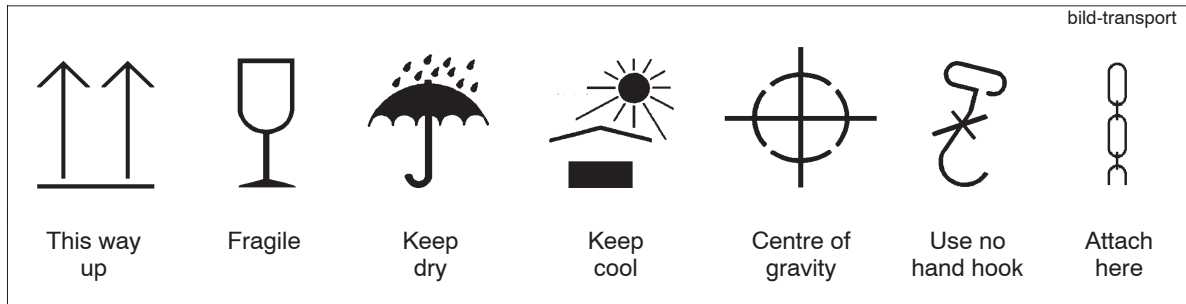

### Caution!

**The oil supply system or assembled unit must always be transported with due care to avoid injury to persons and damage to the unit.**

### Note:

The oil supply system or assembled unit must be transported using suitable transport equipment only.  
The oil supply system is to be transported without an oil charge.

### Caution!

**To transport and handle gear units with attached oil supply systems, use only the lifting eyes specially provided for this purpose on the gear units. The position of the attachment points is shown in the documentation of the gear unit for each specific order.**

### Caution!

**When handling the separate oil supply system, exercise special care to avoid damage due to the use of force or careless loading and unloading. To transport and handle the oil supply system, use ropes or chains. Only the designated lifting eyes on the base frame must be used for fastening. Care must be taken that the carrier ropes do not damage fittings and piping. A cross-beam is therefore required for protection. The lengths of the ropes must be set to ensure that the base frame is suspended horizontally.**

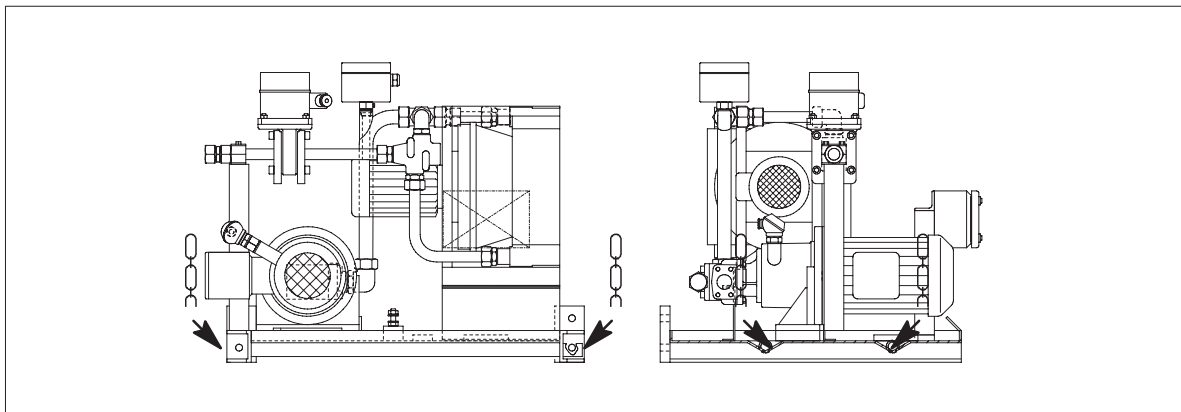

## 4.3 Storage of the oil supply system

The oil supply system or assembled unit must be stored in the position of use on a vibration-free wooden base in a sheltered place and covered over.



**Do not stack oil supply systems or assembled units one on top of another.**

### Caution!

**If the oil supply system or assembled unit is being stored out of doors, it must be very carefully covered over and care must be taken that neither moisture nor foreign material can collect on the drive.**

**Note:** Provision for special environmental conditions during transport (e.g. transport by ship) and storage (climate, termites, etc.) must be contractually agreed.

The openings must be sealed with plugs or flanged covers.

## 4.4 Standard corrosion protection

The oil-supply system is provided with an internal preservation.

The characteristics of the external coat depend on the ambient conditions stipulated in the order relating to method of transport and area of application.



**Oil-supply systems are normally delivered completely finished, with a priming and finish coat.**

**They comply with the requirements for the conductivity of the coating and the limitation of the layer thickness of the applied coating in accordance with DIN EN 13463-1. The permissible maximum coating thickness depends on the indicated explosion group (IIA or IIB or IIC) in accordance with DIN EN 50014. Where coatings have a layer thickness less than 200 µm, no electrostatic charge is to be expected.**

**Where oil-supply systems are delivered with a priming coat only, the customer is obliged to apply a finish coat in accordance with the above-mentioned directive.**

**Note:** Ensure that the coat is not damaged!

Any damage may cause failure of the external protective coating and corrosion.

**Note:** Unless otherwise contractually agreed, the interior preservation is guaranteed for 6 months, provided that storage is in dry, frostfree sheds.

The guarantee period starts on the date of delivery.

For longer periods of storage (> 6 months) we advise regular checking and, if necessary, renewal of the interior preservation (see section 7, "Start-up").

## 5. Technical description

Observe the "Safety instructions" in section 3.

### 5.1 General

**Note:** The Operating Instructions (BA) for the gear unit must be observed.

The oil supply system specified below serves to cool the oil and/or lubricate gear units (see section 1, "Technical Data").



**Before starting up the monitoring devices must in all cases be connected.**

- The oil supply is ensured by a battery of pumps.
- The pump sucks the oil out of the gear unit oil sump via a suction pipe.
- A filter to filter the circulating oil is installed in the oil circuit (exception: variant 3).
- Heat generated by losses and not removable by convection is removed via an air oil-cooler.
- Filtered and re-cooled oil is then resupplied to the gear unit via a pressure line.
- The above described components are mounted on a base frame of the oil supply system.

**Note:** For control instructions, refer to section 8, "Operation".

Observe for this the drawings and the list of equipment. The components specified in the list of equipment can also be found on the drawings with the part number.



**The direction of discharge of the pump used is dependent upon the direction of rotation.**

**The direction of rotation of the motors must correspond to the direction of the arrow on the pump.**

### 5.2 Marking the oil supply system for explosion protection

**Note:** Oil supply systems which are intended for use in potentially explosive environments must bear the following markings on the rating plate:

**CE** (see item 1.2)

### 5.3 Service conditions

The oil supply system is suited for service conditions in accordance with Directive 94/9/EC.

Equipment group II (use above ground) of category 3 for areas where there are explosible gas, vapour, mist, air mixtures.

The permissible temperature class or the maximum surface temperature of the oil supply system are assigned according to the max. ambient temperature in the direct vicinity of the oil supply system.

Ambient temperature	Temperature class	max. surface temperature
max. 40 °C	T4	less than 120 °C

**Note:** Observe also item 1.4.

## 6. Mounting



**The oil supply system must not be installed in an explosible environment. Unauthorized access to the oil supply system not permissible.**

Observe the "Safety instructions" in section 3.

### 6.1 General

**Note:** The Operating Instructions (BA) for the gear unit must be observed.

All preserved flange surfaces must be washed down with a solvent, e.g. petroleum ether.



**Environmental protection requirements must be observed.**

- If connection pipes are not supplied with the system, at least seamlessly drawn and bright normalised (NBK) pipes of ST 35.4 in accordance with DIN 2391 c (hydraulic tubing, quality grade C) must be used.
- The interfaces must be provided with the appropriate flanges or screw connections.
- For connection pipes we recommend using compensators to insulate against vibration and compensate for stretching.
- Pipe fastenings (plastic clips) must be used to install piping. The distance between clips must be less than 2 m / 78.7".
- Make sure the piping is not twisted.
- After installation the pipes must be flushed out. Welded pipes must be pickled.
- The motors and monitoring equipment must be connected up electrically in accordance with terminal diagrams, equipment lists and regulations. Check voltage and circuits.
- The plugs and flange covers must be removed and the separately supplied fittings fitted to the system in accordance with the lubrication plan and drawings (see section 1, "Technical Data").
- Separately supplied parts with a screw connection must be carefully cleaned and sealed with LOCTITE 128068.

### 6.2 Check before start-up

- Observe rating plate indication!
- Check that voltage and frequency of the motor correspond to the mains supply values!
- Check that the motor is properly protected!
- Check that the electrical connections are properly tightened and the monitoring equipment is properly connected and set!
- Check that air inlet holes and cooling surfaces are clean!
- Check that protective measures have been taken!
- Execute EARTH acc. to DIN EN 50014!
- Check that the terminal box cover is closed and the line inlets are properly sealed!

**Caution!**

**Connections must be carried out by a specialist in accordance with the current safety regulations. The relevant installation and operating requirements and the usual national and international requirements must be observed.**

### 6.3 General notes on add-on components

**Note:** For operation and maintenance of the components specified in the equipment list, observe the specified operating instructions. For technical data, refer to the list of equipment.

## 6.4 Final installation work

After the gear unit has been installed with the oil supply system, check that all visible screw connections are correctly tightened and, if necessary, retighten.



**Mount necessary safety equipment!**



**The oil supply systems as well as the adjacent piping must be protected against falling objects.**

## 7. Start-up

### **Caution!**

**The oil supply system must not be started up without the required operating instructions being available.**



**If damage has occurred, the oil supply system must not be put into operation.**

Observe the "Safety instructions" in section 3.

### 7.1 Oil viscosity / oil type

For the oil viscosity and oil type, refer to the operating instructions or the gear unit rating plate.

The oil supply systems are designed for oil viscosities < 5 000 cSt at minimum starting temperature (see rating plate ⑨).

### 7.2 Oil filling

**Note:** The Operating Instructions (BA) for the gear unit must be observed.

To remove preservative residues, which could cause the oil to foam, the oil supply system must be flushed out together with the gear unit before starting up.

Before starting up the gear unit/oil supply system must be filled with oil. After filling the filling holes must be correctly closed and sealed.

### **Caution!**

**For the oil viscosity and oil type, refer to the operating instructions or the gear unit rating plate.**

The oil must then be carefully drained out of the oil supply system, the monitoring equipment and the oil chambers in the gear unit, while it is warm. It may be re-used only as flushing oil. The flushing oil must be cleaned before re-use.



**There is a danger of scalding from the hot oil emerging from the housing. Wear protective gloves to avoid scalding.**

### **Caution!**

**Remove any oil spillage immediately with an oil-binding agent.**

Oil must be put into the oil supply system via the gear unit (see operating instructions for "Gear Unit"). Care must be taken that no dirt can get into the oil circuit.

Oil must be poured in until it is level with the mark on the oil level indicator, while the pump is not operating (see operating instructions for "Gear Unit"). The pump can then be started.

### **Caution!**

**Start oil supply system 1 minute before the gear unit. Never operate the gear unit without the oil supply system!**

Before starting up the gear unit for the first time the oil supply system must be run for at least 15 minutes to fill all the oil chambers (see operating instructions for "Gear Unit"). Then shut down the oil supply system and, if necessary, correct the oil level).

All piping - particularly suction pipes (inadmissible air intake) - as well as all screw connections and flanges must be retightened. Leaks must be resealed.

## 7.3 Pump



**The direction of discharge of the pump used is dependent upon the direction of rotation.**  
**The direction of rotation of the motors must correspond to the direction of the arrow on the pump.**

As regards the pump, the specific operating instructions of the manufacturer must be observed.

## 7.4 Air oil-cooler

For the air oil-cooler, the space required for the intake of cooling air must be adhered to by the purchaser/operator in accordance with the drawings in the oil supply system documentation.

As regards the air oil-cooler, the specific Operating Instructions of the manufacturer must be observed.

## 7.5 General notes on add-on components

**Note:** For operation and maintenance of the components specified in the equipment list, observe the specified operating instructions.  
For technical data, refer to the list of equipment.

## 7.6 Start-up

Before starting up the oil supply system check whether these operating instructions and the operating instructions for the gear unit have been correctly adhered to.

### Caution!

**In all cases oil must be put in before starting up.**  
**The cooling air circuit must be checked before starting up!**  
**Shut-off valves must be secured against unintentional closing.**

All impurities must be removed from the oil supply system before starting up and after repair and maintenance work. This applies particularly to water (e.g. rainwater) to prevent an oil-water mixture.

All pumps, filters and coolers must be ventilated.



**Pressure relief valve/safety valve pressure settings made by FLENDER at its works must not be altered, as they are not used to control the pressure and the flow rate. They serve only as a protection against overload.**

## 7.7 Removal from service

- To remove the oil supply system from service, it must be shut off.



**Secure the oil supply system to prevent it from being started up unintentionally.**  
**Attach a warning notice to the start switch!**

## 7.7.1 Interior protection with preservative agent

Oil supply systems with forced lubrication should be run idle with preservative prior to any long-term storage.

Duration of protection	Preservative agent	Special measures
up to 6 months	Castrol Alpha SP 220 S	None
up to 24 months		Close connection pipes
For storage periods longer than 24 months the oil supply system must be re-preserved. For storage periods longer than 36 months, FLENDER should be consulted before.		

Table 7.1: Preservation procedure when using mineral oil or PAO-based synthetic oil

Duration of protection	Preservative agent	Special measures
up to 6 months	Special anti-corrosion oil TRIBOL 1390 1)	None
up to 36 months		Close connection pipes
For storage periods longer than 36 months, FLENDER should be consulted before.		

Table 7.2: Preservation procedure when using PG-based synthetic oil

1) Resistant to tropical conditions and sea water. Max. ambient temperature 50 °C

## 7.7.2 Interior preservation procedure

- Remove the oil supply system from service and drain off the oil.
- Fill the oil supply system (if necessary, via the connected gear unit) with a sufficient quantity of preservative agent as indicated in Table 7.1 or 7.2.
- Start the oil supply system and allow it to idle for a short time.
- Drain off the preservative agent into a suitable receptacle and dispose of the oil in accordance with the regulations.



**There is a risk of scalding from the hot preservative agent draining from the gear unit. Wear protective gloves!**

## 8. Operation

Observe the "Safety instructions" in section 3.

**Note:** The operating instructions (BA) for the gear unit must be observed.



**The oil supply systems as well as the adjacent piping must be protected against falling objects.**

### 8.1 Lubrication diagram

For the relevant lubrication diagram drawing number, refer to the list of equipment.

### 8.2 Oil viscosity / oil type

For the oil viscosity and oil type, refer to the operating instructions or the gear unit rating plate.

The oil supply systems are designed for oil viscosities < 5 000 cSt at minimum starting temperature (see rating plate ⑨).

## 8.3 Control information

The part numbers (...) given in the following text have been taken from the list of equipment, assembly drawing and the lubrication diagram.

The following control information must be noted for the individual components:

**Note:** In addition to this control information, the specifications in the enclosed equipment list must always be observed.

Only the control information of the part numbers shown in the list of equipment applies to the delivered oil supply system. For the specific switching points and/or values, refer to the list of equipment.

### 8.3.1 Pump (10)

When the pump is operating, the system pressure is limited by a pressure relief valve integrated into the pump.

**Caution!**

**The factory adjustment of this valve must not be changed!**



**The monitoring devices ensure that no overheating occurs due to dry running of the pump.**

### 8.3.2 Temperature monitor (17)

The temperature in the oil supply system is monitored by means of temperature monitor.

### 8.3.3 Filter (20)

The filter is monitored visually by means of a differential pressure indicator and electrically by means of a differential pressure monitor.

### 8.3.4 Temperature-control valve (32)

A temperature control valve is located in the by-pass of the air oil-cooler. At an oil temperature of  $T = 45\text{ °C}$  (size 9 =  $49\text{ °C}$ , size 10 =  $52\text{ °C}$ ) the valve begins to release the flow to the cooler. At  $T = 60\text{ °C}$  the entire oil quantity flows over the cooler.

### 8.3.5 Pressure gauge (45)

The oil pressure is indicated visually by means of a pressure gauge.

### 8.3.6 Pressure monitor (50, 55)

The pressure in the oil supply system is monitored by means of pressure monitor.

### 8.3.7 Thermometer (60)

The oil temperature is indicated visually by means of a thermometer.

### 8.3.8 Temperature monitor (70)

The temperature of the system is monitored by means of a temperature monitor.

### 8.3.9 Temperature monitor (75)

The fan motor of the air oil-cooler is switched via a temperature monitor.

### 8.3.10 Volume flow meter (80)

The oil flow is monitored by means of a volumetric flow meter.

### 8.3.11 General

For the pressure monitors and the flow monitor a delay time of 10 seconds should be provided.

After switching off the main drive the oil supply system must continue to run until the drive has come to a complete standstill.



8.4 Interlocking specifications when using as a pressure lubrication system

8.4.1 Fan motor

**FAN MOTOR ON** is given when the following condition is fulfilled:

Oil temperature > switching point (75.1)

**FAN MOTOR OFF** is given when the following condition is fulfilled:

Oil temperature < switching point (75.2)

8.4.2 Pump enable

**PUMP ENABLE** is given when the following condition is fulfilled:

Oil temperature < switching point (70.1)

8.4.3 Gear unit enable

**GEAR UNIT ENABLE** is given when the following conditions are fulfilled:

Oil flow quantity > switching point (80.1)

Oil pressure > switching point (55)

Oil temperature < switching point (70.1)

Filter differential pressure < switching point (20)

Run-up time of oil supply system at least 2 minutes (in the case of circulating oil lubrication).

8.4.4 Warning

**WARNING** is given when one of the following conditions is fulfilled:

Pump temperature > temperature value (10.1)

Oil flow quantity < switching point (80.1)

Oil pressure < switching point (55)

Oil temperature > switching point (70.1)

Filter differential pressure > switching point (20) after a period of 30 s

8.4.5 Gear unit stop

**GEAR UNIT STOP** is given when one of the following conditions is fulfilled:

Pump temperature > temperature value (10.2)

Motor temperature > temperature value (10.3)

Motor temperature > temperature value (30.1)

Oil flow quantity < switching point (80.2)

Oil pressure < switching point (50)

Oil temperature > switching point (70.2)

Oil temperature > switching point (17.1)

If, when **GEAR UNIT STOP** is given, the oil temperature is > switch point (70.2), the pump must be set to remain on up to an oil temperature < switch point (70.1).

## 8.5 Response to malfunctions



**Irrespective of the following information, the local safety requirements will apply in all cases for operation of the oil supply system.**

Monitoring during operation is essential to identify any malfunctions occurring (see Section 9, "Disturbances, reasons and remedy") and thus to implement preventive measures. The operating pressures and oil temperatures should be recorded regularly.

If irregularities at variance with the normal condition are noticed during operation, or if the operating data change, it is essential that the cause be identified immediately. If necessary, shut the system off. If the causes cannot be identified, even with the aid of the Troubleshooting List, inform FLENDER at once (see Section 11, "Stocking spare parts, service facility addresses").



**We URGENTLY recommend that a lockable emergency switch be provided to ensure that the system is secured to prevent accidental switch-on during maintenance, repairs, or malfunctions. In addition, we would draw attention to the relevant accident prevention regulations on site!**

For restart after malfunction, the information in Section 7, "Start-up" should be noted.

## 8.6 Shut-down

If the gear unit and oil supply system are shut down for longer periods, the following measures are necessary:

- a) Gear unit and oil supply system should remain filled with oil. Every 4 weeks gear unit and oil supply system must be run for 1 hour. The necessary prelubrication and lubrication times should be observed.
- b) If the measures listed under a) are not possible, the gear unit and the oil supply system (see section 7, "Start-up") must be preserved.

Please also observe the Operating Instructions of the gear unit.

## 9. Faults, causes and remedy

Observe the "Safety instructions" in section 3.

### 9.1 General information on faults and malfunctions

**Note:** The Operating Instructions (BA) for the gear unit must be observed.

**Note:** Faults and malfunctions occurring during the guarantee period and requiring repair work on the oil supply system must be carried out only by the FLENDER Customer Service.

In the case of faults and malfunctions occurring after the guarantee period and whose cause cannot be precisely identified, we advise our customers to contact our customer service.

#### Caution!

**FLENDER will not be bound by the terms of the guarantee or warranty or otherwise be responsible in cases of improper use of the oil supply system, modifications on the oil supply system carried out without FLENDER's agreement, or use of spare parts not supplied by FLENDER.**



**When remedying faults and malfunctions, the oil supply system must always be taken out of service.**

**Secure the drive unit to prevent it from being started up unintentionally. Attach a warning notice to the start switch!**

# FLENDER

## 9.2 Possible faults

Malfunctions	Causes	Remedy
Oil temperature too high.	Cooler motor not running.  Air in cooler.  Cooler fouled up.	Check current feed to cooler motor or temperature monitor and, if necessary, repair or replace.  Vent cooler.  Clean or replace cooler. See separate Operating Instructions (BA).
Oil temperature too low.	Gear unit has not yet heated up.	Wait.
Oil pressure too low.	Filter clogged.  Pressure relief valve incorrectly set.  Pressure relief valve defective.  Suction line clogged.  Pump is drawing in air.  Oil temperature too high.  Oil viscosity too low.  Pump defective, pump drive defective.	Switch filter over to clean filter and clean or replace filter element. See separate Operating Instructions (BA).  Contact FLENDER.  Repair or replace pressure relief valve. See separate Operating Instructions (BA).  Clean suction pipe.  Check suction line and repair any leaks.  See there.  Check oil viscosity and, if necessary, put in correct oil.  Repair or replace pump. See separate Operating Instructions (BA).
Oil pressure too high.	Gear unit has not yet heated up.  Pressure relief valve incorrectly set.  Pressure relief valve defective.  Oil pipes to and on gear unit clogged.  Oil viscosity too high.	Wait.  Contact FLENDER.  Repair or replace pressure relief valve. See separate Operating Instructions (BA).  Find and clean clogged line.  Check oil viscosity and, if necessary, put in correct oil.

# FLENDER

Malfunctions	Causes	Remedy
Unusual or increased filter residues.	Pipes dirty (scale, welding residues).	Clean the pipes.
	Abraded material from gear unit.	Check gear unit (bearings, teeth, alignment) and repair defects.
	Oil contaminated.	Change oil.
	Abraded material from defective pump.	Repair or replace pump. See separate Operating Instructions (BA).
Oil consumption too high.	Leak in pipes, connections, valves or gear unit.	Tighten screws. Reseal.
	Shaft outlets on gear unit leaky.	Replace sealing rings.
	Cooler leaky.	Seal or renew cooler. See separate Operating Instructions (BA).
	Filter leaky.	Seal filter.

Table 9.2: Faults, causes and remedies

## 9.2.1 Possible faults when installing the oil supply system

- Important information for describing the drive and the environment are not communicated.
- Performance data too high.
- Chemically aggressive environment not taken into consideration.
- The ambient temperature is not permissible.
- Components with transport or other damage are being fitted.
- Loosely supplied parts are interchanged.
- Prescribed tightening torques are not being adhered to.
- The coating used is not suitable for operation within the meaning of the explosion protection requirements or of Directive 94/9/EC.
- Operating conditions are being changed without authorisation.

## 9.2.2 Possible faults in maintenance

- Maintenance intervals are not being adhered to.
- Leakage in the vicinity of the oil supply system is not being identified and as a result chemically aggressive media are damaging the oil supply system.

## 10. Maintenance and repair

Observe the "Safety instructions" in section 3.

**Note:** The Operating Instructions (BA) for the gear unit must be observed.



**The oil supply systems as well as the adjacent piping must be protected against falling objects.**

### 10.1 Oil viscosity / oil type

For the oil viscosity and oil type, refer to the operating instructions or the gear unit rating plate.

The oil supply systems are designed for oil viscosities < 5 000 cSt at minimum starting temperature (see rating plate ⑨).

For the oil change intervals, please refer to the operating instructions (BA) for the gear unit.

### 10.2 General notes on add-on components

**Note:** For operation and maintenance of the components specified in the equipment list, observe the specified operating instructions. For technical data, refer to the list of equipment.

### 10.3 Preservation

Refer to Section 7, "Start-up", and Section 8, "Operation".

### 10.4 Cleaning



**To prevent the build-up of dust on the oil supply system, cleaning must be done in accordance with operating conditions.**

## 11. Spare parts, customer-service addresses

### 11.1 Stocking spare parts

By stocking the most important spare and wearing parts on site you can ensure that the oil supply system is ready for use at any time.

**Caution!**

**We guarantee only the original spare parts supplied by us. Non-original spare parts have not been tested or approved by us. They may alter technical characteristics of the oil-supply unit, thereby posing an active or passive risk to safety. FLINDER will assume no liability or guarantee for damage caused by spare parts and accessories not supplied by FLINDER. The same applies to any accessories not supplied by FLINDER.**

Please note that certain components often have special production and supply specifications and that we supply you with spare parts which comply fully with the current state of technical development as well as current legislation.

To order spare parts, refer to the list of equipment.

When ordering spare parts, always state the following:

Material no. of the oil supply system	Production order	Part no.	Quantity
---------------------------------------	------------------	----------	----------

### 11.2 Spare parts and customer service addresses

When ordering spare parts or the services of our specialist engineers, apply first to FLINDER AG.

## Adressen - Deutschland (2007-08-17)

<b>A. Friedr. Flender AG</b>	<b>Alfred-Flender-Straße 77</b> 46395 Bocholt	<b>Postfach 1364</b> 46393 Bocholt	<b>Tel.: (0 28 71) 92 - 0</b> <b>Fax: (0 28 71) 92 - 25 96</b>	<b>contact@flender.com</b> <b>www.flender.com</b>
<b>A. Friedr. Flender AG</b> Kundenservice Center Nord	Alfred-Flender-Straße 77 46395 Bocholt	Postfach 1364 46393 Bocholt	Tel.: (0 28 71) 92 - 0 Fax: (0 28 71) 92 - 14 35	ksc.nord @flender.com www.flender.com
<b>A. Friedr. Flender AG</b> Kundenservice Center Süd	Weissacherstraße 11	70499 Stuttgart	Tel.: (07 11) 1 37 24 37 Fax: (07 11) 1 37 39 40	ralph.keppler @siemens.com www.flender.com
<b>A. Friedr. Flender AG</b> Kundenservice Center Süd	Richard-Strauss-Straße 76	80286 München	Tel.: (0 89) 92 21 36 27 Fax: (0 89) 92 21 30 89	michael.singer @siemens.com www.flender.com
<b>A. Friedr. Flender AG</b> Kundenservice Center Ost	Rohrdamm 83	13629 Berlin	Tel.: (0 30) 38 63 07 08 Fax: (0 30) 38 63 21 16	elke.heilemann @siemens.com www.flender.com
<b>A. Friedr. Flender AG</b> Werk Friedrichsfeld	Am Industriepark 2	46562 Voerde	Tel.: (0 28 71) 92 - 0 Fax: (0 28 71) 92 - 25 96	contact@flender.com www.flender.com
<b>A. Friedr. Flender AG</b> Werk Wesel	Brüner Landstraße 5	46485 Wesel	Tel.: (02 81) 98 81 - 0 Fax: (02 81) 98 81 - 12 40	contact@flender.com www.flender.com
<b>Flender Industriegetriebe GmbH &amp; Co. KG</b>	Thierbacher Straße 24 09322 Penig	09320 Penig	Tel.: (03 73 81) 60 Fax: (03 73 81) 8 02 86	ute.tappert@flender.com www.flender.com
<b>A. Friedr. Flender AG</b> Kupplungswerk Mussum	Industriepark Bocholt Schlavenhorst 100	46395 Bocholt	Tel.: (0 28 71) 92 - 28 68 Fax: (0 28 71) 92 - 25 79	couplings@flender.com www.flender.com
<b>Flender Guss GmbH &amp; Co. KG</b>	Obere Hauptstraße 228 - 230	09228 Chemnitz/ Wittgensdorf	Tel.: (0 37 22) 64 - 0 Fax: (0 37 22) 94 - 1 38	flender.guss@ flender-guss.com www.flender-guss.de
<b>Winergy AG</b>	Am Industriepark 2 46562 Voerde	Postfach 201160 46553 Voerde	Tel.: (0 28 71) 92 - 4 Fax: (0 28 71) 92 - 24 87	info@winergy-ag.com www.winergy-ag.com
<b>Flender Tübingen GmbH</b>	Bahnhofstraße 40 - 44 72072 Tübingen	Postfach 1709 72007 Tübingen	Tel.: (0 70 71) 7 07 - 0 Fax: (0 70 71) 7 07 - 4 00	sales-motox@ flender-motox.com www.flender.com
<b>Loher GmbH</b>	Hans-Loher-Straße 32 94099 Ruhstorf	Postfach 1164 94095 Ruhstorf	Tel.: (0 85 31) 39 - 0 Fax: (0 85 31) 39 - 4 37	info@loher.de www.loher.de
<b>A. Friedr. Flender AG</b> Service International	<b>Werk Friedrichsfeld</b> Am Industriepark 2 46562 Voerde	Postfach 201160 46553 Voerde	Tel.: (0 28 71) 92 - 24 02 Fax: (0 28 71) 92 - 15 17	werner.vahlenkamp @siemens.com www.flender-service.com
	24h Service Hotline		+49 (0) 17 22 81 01 00	
	<b>Werk Herne</b> Südstraße 111 44625 Herne	Postfach 101720 44607 Herne	Tel.: (0 23 23) 9 40 - 1 01 Fax: (0 23 23) 9 40 - 3 33	infos@flender-service.com www.flender-service.com
	<b>Werk Penig</b> Thierbacher Straße 24 09322 Penig	Postfach 44/45 09320 Penig	Tel.: (03 73 81) 61 - 5 20 Fax: (03 73 81) 61 - 4 88	reinhard.mehner @siemens.com www.flender-service.com

## Addresses - International

(2007-08-17)

EUROPE					
<b>AUSTRIA</b>	Siemens AG Österreich Automation & Drives	Postfach 83 Siemensstrasse 90-92	1211 Wien 1210 Wien	Phone: +43 (0) 5 - 17 07-0 Fax: +43 (0) 5 - 17 07 5 50 20	josef.wistrcil@siemens.com www.siemens.at/ad
<b>BELGIUM &amp; LUXEMBOURG</b>	Siemens n.v./s.a. Energy - Industry - Transport Automation & Drives IPS	Gebäude: 43/+2 Guido Gezellestraat 121	1654 Huizingen Beersel	Phone: +32 (0) 2 - 5 36 99 17 Fax: +32 (0) 2 - 5 36 22 06	mechanical_drives.be @siemens.com www.siemens.be
<b>BULGARIA</b>	Auto - Profi N GmbH	102, Bulgaria Boul. Business Center "Bellissimo" Office 48	1680 Sofia	Phone: +359 (0) 2 - 8 54 94 40 Fax: +359 (0) 2 - 8 54 94 46	flender@auto-profi.com
<b>CROATIA / SLOVENIA BOSNIA - HERZEGOVINA</b>	HUM - Naklada d.o.o.	Mandroviceva 3a	10000 Zagreb	Phone: +385 (0) 1 - 2 30 60 25 Fax: +385 (0) 1 - 2 30 60 24	bozo.markota@zg.t-com.hr
<b>CZECH REPUBLIC</b>	Siemens s.r.o. Automation & Drives	Fibichova 218	27601 Melnik	Phone: +420 315 - 62 12 20 Fax: +420 315 - 62 12 22	petr.pumprla@siemens.com
<b>DENMARK</b>	Siemens A/S	Borupvang 3	2750 Ballerup	Phone: +45 - 44 77 44 77 Fax: +45 - 44 77 40 19	ad-ekspedition.dk @siemens.com www.siemens.dk/gear
<b>ESTHONIA</b>	AS Siemens Automation & Drives	Pärnu mnt. 139 C	11 317 Tallinn	Phone: +372 - 6 30 88 41 Fax: +372 - 6 30 88 89	artur.jakimenko@siemens.com www.siemens.ee
<b>FINLAND</b>	Siemens Osakeyhtiö	P.O. Box 60 Majurinkatu 6	02601 Espoo 02600 Espoo	Phone: +358 (0) 10 - 5 11 51 51 Fax: +358 (0) 10 - 5 11 39 99	admyynti.fi@siemens.com www.siemens.fi/ad
<b>FRANCE</b>	Siemens S.A.S. Automation & Drives	3, rue Jean Monnet - B.P. 5	78996 Elancourt Cedex	Phone: +33 (0) 1 - 30 66 39 00 Fax: +33 (0) 1 - 30 66 32 67	contact.flender.fr@siemens.com www.siemens.fr
	Siemens S.A.S. Automation & Drives	Sales Office Parc Inopolis, Route de Vourles	69230 Saint Genis Laval	Phone: +33 (0) 4 - 72 83 95 20 Fax: +33 (0) 4 - 72 83 95 39	contact.flender.fr@siemens.com www.siemens.fr
<b>FRANCE</b>	Flender-Graffenstaden SA	1, rue du Vieux Moulin	67400 Illkirch - Graffenstaden	Phone: +33 (0) 3 - 88 67 60 00 Fax: +33 (0) 3 - 88 67 06 17	flencomm@flender-graff.com www.siemens.fr
<b>GREECE ALBANIA MACEDONIA</b>	Siemens A.E. Automation & Drives	P.O. Box 61011 Artemidos 8	15110 Amaroussio Athens 15125 Amaroussio Athens	Phone: +30 210 - 6 86 43 94 Fax: +30 210 - 6 86 43 88	stefanos.stamidis @siemens.com www.siemens.gr
<b>HUNGARY</b>	Siemens Zrt. Automation & Drives	Gizella út 51-57	1143 Budapest	Phone: +36 1 - 4 71 19 65 Fax: +36 1 - 4 71 17 04	laszlo.jambor@siemens.com www.siemens.hu/ad
<b>IRELAND</b>	Siemens Ltd. Automation & Drives	Leeson Close	Dublin 2	Phone: +353 (0) 1 - 2 16 24 00 Fax: +353 (0) 1 - 2 16 24 99	domhnall.carroll@siemens.com
<b>ITALY</b>	Siemens S.p.A. Automation & Drives	Viale Piero e Alberto Pirelli, 10	20126 Milano	Phone: +39 (0) 02 - 24 31 Fax: +39 (0) 02 - 24 36 22 12	domenico.beretta @siemens.com www.siemens.it/ad
<b>LATVIA</b>	Siemens SIA Automation & Drives	Lidostas "Riga" teritorija Marupes pagasts, Rigas rajons	1053 Riga	Phone: +371 - 67 01 55 00 Fax: +371 - 67 01 55 01	siemens.lv@siemens.com www.siemens.lv
<b>LITHUANIA</b>	UAB Siemens Automation & Drives	J. Jasinskio str. 16c	01112 Vilnius	Phone: +370 5 - 2 39 15 00 Fax: +370 5 - 2 39 15 01	sergejus.gaizauskas @siemens.com www.siemens.lt
<b>THE NETHERLANDS</b>	Siemens Nederland N.V. Industry - Motion Control & Drives	Lokatie K2.3 Prinses Beatrixlaan 800 Postbus 16068	2595 BN Den Haag 2500 BB Den Haag	Phone: +31 (0) 70 - 3 33 69 74 Fax: +31 (0) 70 - 3 33 12 12	salesflender.nl@siemens.com www.siemens.nl
<b>THE NETHERLANDS</b>	Bruinhof B.V.	Boterdiep 37 Postbus 9607	3077 AW Rotterdam 3007 AP Rotterdam	Phone: +31 (0) 10 - 4 97 08 08 Fax: +31 (0) 10 - 4 82 43 50	info@bruinhof.nl www.bruinhof.nl
<b>NORWAY</b>	Siemens AS Divisjon Automation & Drives	Østre Aker vei 90 Postboks 1	0596 Oslo 0613 Oslo	Phone: +47 - 22 63 30 00 Fax: +47 - 22 63 31 05	adinfo@siemens.no www.siemens.no/ad
<b>POLAND</b>	Siemens Sp. z o.o. Automation & Drives	Ul. Gawronów 22	40-527 Katowice	Phone: +48 (0) 32 - 2 08 42 35 Fax: +48 (0) 32 - 2 08 43 39	marcin.walter@siemens.com www.siemens.pl/flender
<b>PORTUGAL</b>	Siemens, S.A. Automation & Drives	Rua Irmãos Siemens, 1	2720-093 Amadora	Phone: +351 (0) 21 - 4 17 83 87 Fax: +351 (0) 21 - 4 17 80 50	alexandre.kisslinger @siemens.com www.siemens.pt/ad
<b>ROMANIA</b>	CN Industrial Group SRL	Str. Vatra Luminoasa 108 Sector 2	021919 Bucuresti	Phone: +40 (0) 21 - 2 52 98 61 Fax: +40 (0) 21 - 2 52 98 60	office@flender.ro office@inacn.ro www.inacn.ro
<b>RUSSIA</b>	A. Friedr. Flender AG Akkreditierte Vertretung	Tjuschina 4-6	191 119 St. Petersburg	Phone: +7 (0) 8 12 - 3 20 90 34 Fax: +7 (0) 8 12 - 3 20 90 82	flendergus@mail.spbnit.ru www.automation-drives.ru
<b>SERBIA - MONTENEGRO</b>	G.P.Inzenjering d.o.o.	Bulevar AVNOJ-a 87/9	11070 Novi Beograd	Phone: +381 (0) 11 - 3 01 78 67 Fax: +381 (0) 11 - 3 11 67 91	flender@eunet.yu gping@eunet.yu
<b>SLOVAKIA</b>	DriveTech s.r.o.	Vajanského 49, P.O. Box 286	08001 Presov	Phone: +421 (0) 9 03 64 60 44 Fax: +421 (0) 51 - 7 70 32 67	micenko.flender@nexta.sk
<b>SPAIN</b>	Siemens, S.A. División Productos y Sistemas Industriales PS1	Ronda de Europa, 5	28760 Tres Cantos Madrid	Phone: +34 (0) 91 - 5 14 80 00 Fax: +34 (0) 91 - 5 14 70 32	ulf.holtkamp@siemens.com www.siemens.es
<b>SWEDEN</b>	Siemens AB	Östergårdsgatan 2-4 Box 14153	43153 Mölndal 40020 Göteborg	Phone: +46 (0) 31 - 7 76 86 00 Fax: +46 (0) 31 - 7 76 86 76	kundcenter.ad.se @siemens.com www.siemens.se/flender
<b>SWITZERLAND</b>	Siemens Schweiz AG Automation & Drives, Motion Control	Freilagerstrasse 28	8047 Zürich	Phone: +41 (0) 8 48 82 28 44 Fax: +41 (0) 8 48 82 28 55	adassistance.ch @siemens.com www.siemens.ch/ad
<b>TURKEY</b>	Siemens Sanayi ve Ticaret A.S. Automation & Drives	Esentepe mahallesi Yakacik Caddesi no. 111	34870 Kartal Istanbul	Phone: +90 (0) 2 16 - 4 59 24 67 Fax: +90 (0) 2 16 - 4 59 22 98	mehmet.kocaoglu @siemens.com
<b>UKRAINE</b>	Siemens Ukraine Automation & Drives	Predslavinska Str., 11-13	03150 Kiev	Phone: +380 44 - 2 01 24 26 Fax: +380 44 - 2 01 24 66	sergey.drachov@siemens.com drives.ua@siemens.com www.siemens.ua/ad
<b>UNITED KINGDOM</b>	Siemens plc Automation & Drives	Thornbury Works, Leeds Road	Bradford West Yorkshire BD3 7EB	Phone: +44 (0) 12 74 - 65 77 00 Fax: +44 (0) 12 74 - 66 98 36	sales-mechanicaldrives.ad.uk @siemens.com www.siemens.co.uk

# FLENDER

AFRICA					
<b>ALGERIA / TUNESIA MOROCCO</b>	Flender S.A.S. Automation & Drives	3, rue Jean Monnet - B.P.5	78996 Elancourt Cedex	Phone: +33 (0) 1 - 30 66 39 00 Fax: +33 (0) 1 - 30 66 35 13	contact.flender.fr@siemens.com
<b>EGYPT</b>	Siemens Limited	55, El Nakhil and El Aenab Street	Mohandessin, Cairo	Phone: +20 (0) 2 - 3 33 36 74 Fax: +20 (0) 2 - 3 33 36 07	hany.loka@siemens.com www.siemens.com.eg
<b>SOUTH AFRICA</b>	Siemens Limited	Cnr. Furnace St. & Quality Rd. P.O. Box 131	Isando - Johannesburg Isando 1600	Phone: +27 (0) 11 - 5 71 20 00 Fax: +27 (0) 11 - 3 92 24 34	dorothy.coetzee@siemens.com
	Siemens Limited	Sales Offices Unit 3 Marconi Park, 9 Marconi Crescent, Montague Gardens P.O. Box 37291	Cape Town Chempet 7442	Phone: +27 (0) 21 - 5 51 50 03 Fax: +27 (0) 21 - 5 52 38 24	dorothy.coetzee@siemens.com
	Siemens Limited	Unit 3 Goshawk Park Falcon Industrial Estate P.O. Box 1608	New Germany - Durban New Germany 3620	Phone: +27 (0) 31 - 7 05 38 92 Fax: +27 (0) 31 - 7 05 38 72	dorothy.coetzee@siemens.com
	Siemens Limited	9 Industrial Crescent, Ext. 25 P.O. Box 17609	Witbank Witbank 1035	Phone: +27 (0) 13 - 6 92 34 38 Fax: +27 (0) 13 - 6 92 34 52	dorothy.coetzee@siemens.com
	Siemens Limited	Unit 14 King Fisher Park, Alton Cnr. Ceramic Curve & Alumina Allee, P.O. Box 101995	Richards Bay Meerensee 3901	Phone: +27 (0) 35 - 7 51 15 63 Fax: +27 (0) 35 - 7 51 15 64	dorothy.coetzee@siemens.com
AMERICA					
<b>ARGENTINA</b>	Siemens S.A.	Calle 122 No. 4785 (ex Gral. Roca) Ruta 8 km 18	Prov. de Buenos Aires	Phone: +54 (0) 11 - 47 38 71 00 Fax: +54 (0) 11 - 47 38 72 71	marcos.cardaci@siemens.com
<b>BRASIL</b>	Flender Brasil Ltda.	Rua Quatorze, 60 Cidade Industrial	CEP: 32211 - 970 Contagem - MG	Phone: +55 (0) 31 - 33 69 21 00 Fax: +55 (0) 31 - 33 69 21 66	vendas@flenderbrasil.com
	Flender Brasil Ltda.	Sales Offices Rua James Watt, 142 - conj. 142 - Brooklin Novo	CEP: 04576 - 050 São Paulo - SP	Phone: +55 (0) 11 - 55 05 99 33 Fax: +55 (0) 11 - 55 05 30 10	flesao@uol.com.br
	Flender Brasil Ltda.	Rua Campos Salles, 1095 sala 04 - Centro	CEP: 14015 - 110 Ribeirão Preto - SP	Phone: +55 (0) 16 - 6 35 15 90 Fax: +55 (0) 16 - 6 35 11 05	flender.ribpreto@uol.com.br
	Flender Brasil Ltda.	Rua Da Mitra - quadra 30 sala 207 - Edificio Cristal - lote 16	CEP: 65075 - 770 São Luis - MA	Phone: +55 (0) 98 - 32 25 84 92 Fax: +55 (0) 98 - 32 25 84 93	flenderslz@uol.com.br
	Flender Brasil Ltda.	Rua Padre Anchieta, 1691 - conj. 1110 - Bairro Bigorriho	CEP: 80730 - 000 Curitiba - PR	Phone: +55 (0) 41 - 3 36 28 49 Fax: +55 (0) 41 - 99 64 24 04	quality.engineer@bol.com.br
<b>CANADA</b>	Siemens Canada Ltd. Automation & Drives	215 Shields Court, Units 4-6	Markham Ontario L3R 8V2	Phone: +1 (0) 9 05 - 3 05 10 21 Fax: +1 (0) 9 05 - 3 05 10 23	bershu.nkwawir@siemens.com www.flender-na.com
<b>CHILE</b>	Siemens S.A. Automation & Drives	Av. Providencia 1760, Piso 11 Edificio Palladio	Santiago de Chile	Phone: +56 (0) 2 - 4 77 10 00 Fax: +56 (0) 2 - 4 77 10 58	r.wagner@siemens.com www.siemens.cl
<b>COLOMBIA</b>	A.G.P. Representaciones Ltda.	Flender Liaison Office Colombia Av Boyaca No. 23 A 50 Bodega UA 7-1	Bogotá	Phone: +57 (0) 1 - 5 70 63 53 Fax: +57 (0) 1 - 5 70 73 35	aguerrero@agp.com.co www.agp.com.co
<b>MEXICO</b>	Siemens S.A. de C.V. Automation & Drives	Poniente 116 No. 590 Col. Industrial Vallejo	02300 México, D.F.	Phone: +52 (0) 55 - 53 28 20 00 Fax: +52 (0) 55 - 53 28 21 92	rafael.galan@siemens.com
	Siemens S.A. de C.V. Automation & Drives	Libramiento Arco Vial Km. 4.2 Santa Catarina	C.P. 66350 Nuevo León	Phone: +52 (0) 81 - 81 24 41 00 Fax: +52 (0) 81 - 81 24 41 12	hector.lugo@siemens.com
<b>PERU</b>	Siemens S.A.C. Automation & Control	Av. Domingo Orué 971 Surquillo	Lima 34	Phone: +51 (0) 1 - 2 15 00 30 Fax: +51 (0) 1 - 4 41 40 47	isaac.maizel@siemens.com
<b>USA</b>	Siemens Energy & Automation, Inc. Power Conversion Division	950 Tollgate Road	Elgin, IL. 60123	Phone: +1 (0) 8 47 - 9 31 19 90 Fax: +1 (0) 8 47 - 9 31 07 11	conny.kramp@siemens.com www.flender-na.com
	Siemens Energy & Automation	Service Location 4234 Foster Ave.	Bakersfield CA. 93308 - 4559	Phone: +1 (0) 6 61 - 3 25 44 78 Fax: +1 (0) 6 61 - 3 25 44 70	karen.peterson@siemens.com www.flender-na.com
<b>VENEZUELA</b>	F. H. Transmisiones S.A.	Urbanización Buena Vista Calle Johan Schafer o Segunda Calle, Municipio Sucre	Petare, Caracas	Phone: +58 (0) 2 - 12 21 52 61 Fax: +58 (0) 2 - 12 21 18 38	fhttransm@telcel.net.ve www.fhtransmisiones.com
ASIA					
<b>BAHRAIN / YEMEN JORDAN / KUWAIT QATAR / LEBANON OMAN / LYBIA / IRAQ</b>	Please refer to: Siemens Sanayi ve Ticaret A.S. Automation & Drives	Esentepe mahallesi Yakacik Caddesi no. 111	34870 Kartal Istanbul	Phone: +90 (0) 2 16 - 4 59 33 09 Fax: +90 (0) 2 16 - 4 59 22 98	meso.tr@siemens.com
<b>BANGLADESH SRI LANKA</b>	Please refer to: Flender Limited	No. 2 St. George's Gate Road 5 <sup>th</sup> Floor	Hastings Kolkata - 700022	Phone: +91 (0) 33 - 2 23 05 45 Fax: +91 (0) 33 - 2 23 18 57	flender@flenderindia.com
<b>PEOPLE'S REPUBLIC OF CHINA</b>	Siemens Mechanical Drive Systems (Tianjin) Co., Ltd.	ShuangHu Rd. - Shuangchen Rd. West, Beichen Economic Development Area (BEDA)	Tianjin 300400	Phone: +86 (0) 22 - 26 98 2 Fax: +86 (0) 22 - 26 97 20 61	www.ad.siemens.com.cn
	Siemens Ltd. Automation & Drives	Beijing Sales Office 6 <sup>th</sup> Floor, Wang Jing Tower B 9, Wangjing Zhonghuan Nan Lu Chaoyang District	Beijing 100102	Phone: +86 (0) 10 - 64 76 45 05 Fax: +86 (0) 10 - 64 76 48 78	www.ad.siemens.com.cn
	Siemens Ltd. Automation & Drives	Shanghai Sales Office 11 F, Marine Tower, No.1 Pu Dong Avenue	Shanghai 200120	Phone: +86 (0) 21 - 38 39 41 24 Fax: +86 (0) 21 - 38 39 23 78	xuening.tao@siemens.com www.ad.siemens.com.cn



# FLENDER

<b>INDIA</b>	Flender Limited	No. 2 St. George's Gate Road 5 <sup>th</sup> Floor	Hastings Kolkata - 700 022	Phone: +91 (0) 33 - 22 23 05 45 Fax: +91 (0) 33 - 22 23 18 57	flender@flenderindia.com
	Flender Limited	Industrial Growth Centre Rakhajungle	Nimpura Kharagpur - 721 302	Phone: +91 (0) 3222 - 23 33 07 Fax: +91 (0) 3222 - 23 33 64	works@flenderindia.com
	Flender Limited	Eastern Regional Sales Office No. 2 St. George's Gate Road 5 <sup>th</sup> Floor	Hastings Kolkata - 700 022	Phone: +91 (0) 33 - 22 23 05 45 Fax: +91 (0) 33 - 22 23 08 30	ero@flenderindia.com
	Flender Limited	Western Regional Sales Office Plot No. 23, Sector 19- C	Vashi Navi Mumbai - 400 705	Phone: +91 (0) 22 - 27 65 72 27 Fax: +91 (0) 22 - 27 65 72 28	wro@flenderindia.com
	Flender Limited	Southern Regional Sales Office No. 4 Mahatma Gandhi Road (VI Floor)	Nungambakkam Chennai - 600 034	Phone: +91 (0) 44 - 28 33 42 90 Fax: +91 (0) 44 - 28 33 31 31	sro@flenderindia.com
	Flender Limited	Northern Regional Sales Office 302 Bhikaji Cama Bhawan 11 Bhikaji Cama Palace	New Delhi - 110 066	Phone: +91 (0) 11 - 41 85 96 56 Fax: +91 (0) 11 - 41 85 96 59	nro@flenderindia.com
<b>INDONESIA</b>	P.T. Siemens Indonesia Automation & Drives	Jalan Jendral Ahmad Yani Kav. B 67-68	Pulomas Jakarta 13210	Phone: +62 (0) 21 - 24 55 55 66 Fax: +62 (0) 21 - 4 71 50 63	bob.wall@siemens.com
<b>IRAN</b>	Siemens Sherkate Sahami Khas Automation & Control Group Automation & Drives	No.32, Taleghani Ave. P.O. Box 15875-4773	Tehran 15936	Phone: +98 (0) 21 - 66 14 44 44 Fax: +98 (0) 21 - 88 94 23 88	houshang.assadzadeh@siemens.com
<b>ISRAEL</b>	Ram Greenshpon	Boaz 3	34487 Haifa	Phone: +972 (0) 52 - 4 76 14 26 Fax: +972 (0) 4 - 8 14 60 37	ram@greenshpon.de www.flender.co.il
<b>JAPAN</b>	Siemens K.K. Automation & Drives	Takanawa Park Tower 17F 3-20-14 Higashi Gotanda Shinagawa-ku	141-8641 Tokyo	Phone: +81 (0) 3 - 54 23 87 05 Fax: +81 (0) 3 - 54 23 87 32	contact_flender_products.skk@siemens.com www.siemens.co.jp/ad
<b>KAZAKHSTAN</b>	Please refer to: A. Friedr. Flender AG Customer Service Center East	Rohrdamm 83	13629 Berlin Germany	Phone: +49 (0) 30 - 38 63 07 08 Fax: +49 (0) 30 - 38 63 21 16	elke.heilemann@siemens.com www.siemens.com
<b>KOREA</b>	Siemens Ltd. Automation & Drives	10th Floor, Asia Tower Building 726, Yeoksam-dong Kangnam-gu	Seoul 135-719	Phone: +82 (0) - 8 05 01 30 00 Fax: +82 (0) 2 - 34 50 71 57	marketing.ad-kr@siemens.com www.siemens.seoul.kr
<b>LEBANON</b>	Please refer to: Siemens Sanayi ve Ticaret A.S. Automation & Drives	Esentepe mahallesi Yakacik Caddesi no. 111	34870 Kartal Istanbul	Phone: +90 (0) 2 16 - 4 59 24 67 Fax: +90 (0) 2 16 - 4 59 22 98	meso.tr@siemens.com
<b>MALAYSIA</b>	Siemens Malaysia Sdn. Bhd. Automation & Drives	Level 1 Reception, CP Tower No. 11, Jalan 16/11 Pusat Dagang Seksyen 16	46350 Petaling Jaya Selangor Darul Ehsan	Phone: +60 (0) 3 - 79 52 51 74 Fax: +60 (0) 3 - 79 57 31 80	lep-ming.soh@siemens.com www.siemens.com.my/ automation
<b>PAKISTAN</b>	Please refer to: A. Friedr. Flender AG	Alfred-Flender Strasse 77	46395 Bocholt	Phone: +49 (0) 28 71 - 92 22 59 Fax: +49 (0) 28 71 - 92 15 16	ludger.wittag@siemens.com
<b>PHILIPPINES</b>	Siemens Inc. Automation & Drives	Door No.3, 2/F Carlos Perez Building A.C. Cortes Avenue, Ibabao	Mandaue City 6014 Cebu	Phone: +63 (0) 2 - 8 14 90 75 Fax: +63 (0) 32 - 3 43 86 41	jun.tumaming@siemens.com
<b>SAUDI ARABIA</b>	South Gulf Sands Est.	Bandaria Area, Dohan Bldg. Flat 3/1, P.O.Box 32150	Al-Khobar 31952	Phone: +966 (0) 3 - 8 87 53 32 Fax: +966 (0) 3 - 8 87 53 31	adelameen@nesma.net.sa
<b>SINGAPORE</b>	Siemens Pte. Ltd. Automation & Drives	The Siemens Center 60 MacPherson Road	Singapore 348615	Phone: +65 (0) - 64 90 65 38 Fax: +65 (0) - 64 90 89 93	soothong.tan@siemens.com www.siemens.com.sg/ad
<b>SYRIA</b>	Misrabi Co & Trading	Mezzeh Autostrade Transportation Building 4/A, 5th Floor P.O.Box 12450	Damascus	Phone: +963 (0) 11 - 6 11 67 94 Fax: +963 (0) 11 - 6 11 09 08	ismael.misrabi@gmx.net
<b>TAIWAN</b>	Siemens Limited Automation & Drives	8F, No.3, Yuan Qu St., Nan Gang District	Taipei 11503	Phone: +886 (0) 2 - 26 52 88 88 Fax: +886 (0) 2 - 26 52 88 14	stella.su@siemens.com www.siemens.com.tw/ automation
<b>THAILAND</b>	Siemens Limited Automation & Drives	Charn Issara Tower II 23th Floor 2922/283 New Petchburi Road	Bangkapi, Huaykwang Bangkok 10310	Phone: +66 (0) 27 - 15 41 41 Fax: +66 (0) 27 - 15 48 41	ADHelpline.TH@siemens.com www.siemens.co.th/a&d
<b>UNITED ARAB EMIRATES</b>	Al-Teros Factories Equip. & Machines Suppliers	Al-Batha Tower, 11th Floor, Office 1103 P.O. Box 60699	Cornish, Sharjah Sharjah	Phone: +971 (0) 6 - 5 74 27 52 Fax: +971 (0) 6 - 5 74 27 51	gears@emirates.net.ae
<b>VIETNAM</b>	Siemens AG Representation Vietnam	The Landmark Building 2nd Floor 5B Ton Duc Thang St., District 1	Ho Chi Minh City	Phone: +84 (0) 8 - 8 25 19 00 Fax: +84 (0) 8 - 8 25 15 80	eddie.chung@siemens.com ha-phuong.thu@siemens.com
<b>AUSTRALIA</b>					
	Siemens Ltd. Industrial Automation & Control	9 Nello Place, P.O.Box 6047	Wetherill Park NSW 2164, Sydney	Phone: +61 (0) 2 - 96 16 67 00 Fax: +61 (0) 2 - 96 16 67 01	sales@flender.com.au www.siemens.com.au
	Siemens Ltd. Industrial Automation & Control	885 Mountain Highway	Bayswater VIC 3153, Melbourne	Phone: +61 (0) 3 - 97 21 20 99 Fax: +61 (0) 3 - 97 21 20 01	sales@flender.com.au www.siemens.com.au
	Siemens Ltd. Industrial Automation & Control	P.O. Box 235 Level 1, Building 2, Citilink Business Centre, 153Campbell Str.	Royal Brisbane Hospital, QLD 4029 Bowen Hills QLD 4006, Brisbane	Phone: +61 (0) 7 - 33 32 83 00 Fax: +61 (0) 7 - 33 32 83 01	sales@flender.com.au www.siemens.com.au
	Siemens Ltd. Industrial Automation & Control	Suite 2 403 Great Eastern Highway	Redcliffe WA 6104, Perth	Phone: +61 (0) 8 - 94 77 41 66 Fax: +61 (0) 8 - 94 77 65 11	sales@flender.com.au www.siemens.com.au
<b>NEW ZEALAND</b>	Siemens Ltd. Industrial Automation & Control	9 Nello Place, P.O.Box 6047	Wetherill Park NSW 2164, Sydney	Phone: +61 (0) 2 - 96 16 67 00 Fax: +61 (0) 2 - 96 16 67 01	sales@flender.com.au www.siemens.com.au

## 12. Declaration by the manufacturer / Declaration of Conformity

### Declaration by the manufacturer

in accordance with EC Engineering Directive 98/37/EC, Appendix II B

We hereby declare that the components described in these Operating Instructions:

**Oil supply systems of type OLGE**

**in design in accordance with Directive 94/9/EC**

are intended for incorporation in a machine, and that it is prohibited to put them into service before verifying that the machine into which they are incorporated complies with the EC Directive (original edition 98/37/EC including any subsequent amendments thereto).

Bocholt, 2007-10-10



\_\_\_\_\_  
Signature (Director Engineering TFE)



## Declaration of conformity

within the meaning of EC Directive 94/9/EC of 23.03.94 and with the legal requirements laid down for its implementation

The manufacturer, A. Friedr. Flender AG, D-46393 Bocholt, declares that the equipment described in these Operating Instructions

## Oil supply systems of type **OLGE**

### in design in accordance with Directive 94/9/EC

is in conformity with Article 1 and Article 8, Paragraph 1 c) of Directive 94/9/EC and complies with the requirements of Directive 94/9/EC and the following standards:

DIN EN 1127-1 : 10-1997  
DIN EN 13463-1: 04-2002  
DIN EN 13463-5: 03-2004  
DIN EN 13463-6: 07-2005  
DIN EN 13463-8: 01-2004  
DIN EN 50014 : 02-2000

Bocholt, 2007-10-10

A handwritten signature in black ink, appearing to be 'R. J. ...', written over a horizontal line.

Signature (Director Engineering TFE)

Bocholt, 2007-10-10

A handwritten signature in black ink, appearing to be 'R. J. ...', written over a horizontal line.

Signature (Director Division TF)