

Operating Instructions

BA 3600.1 EN 07.04

Demounting box for extracting RUPEX bolts

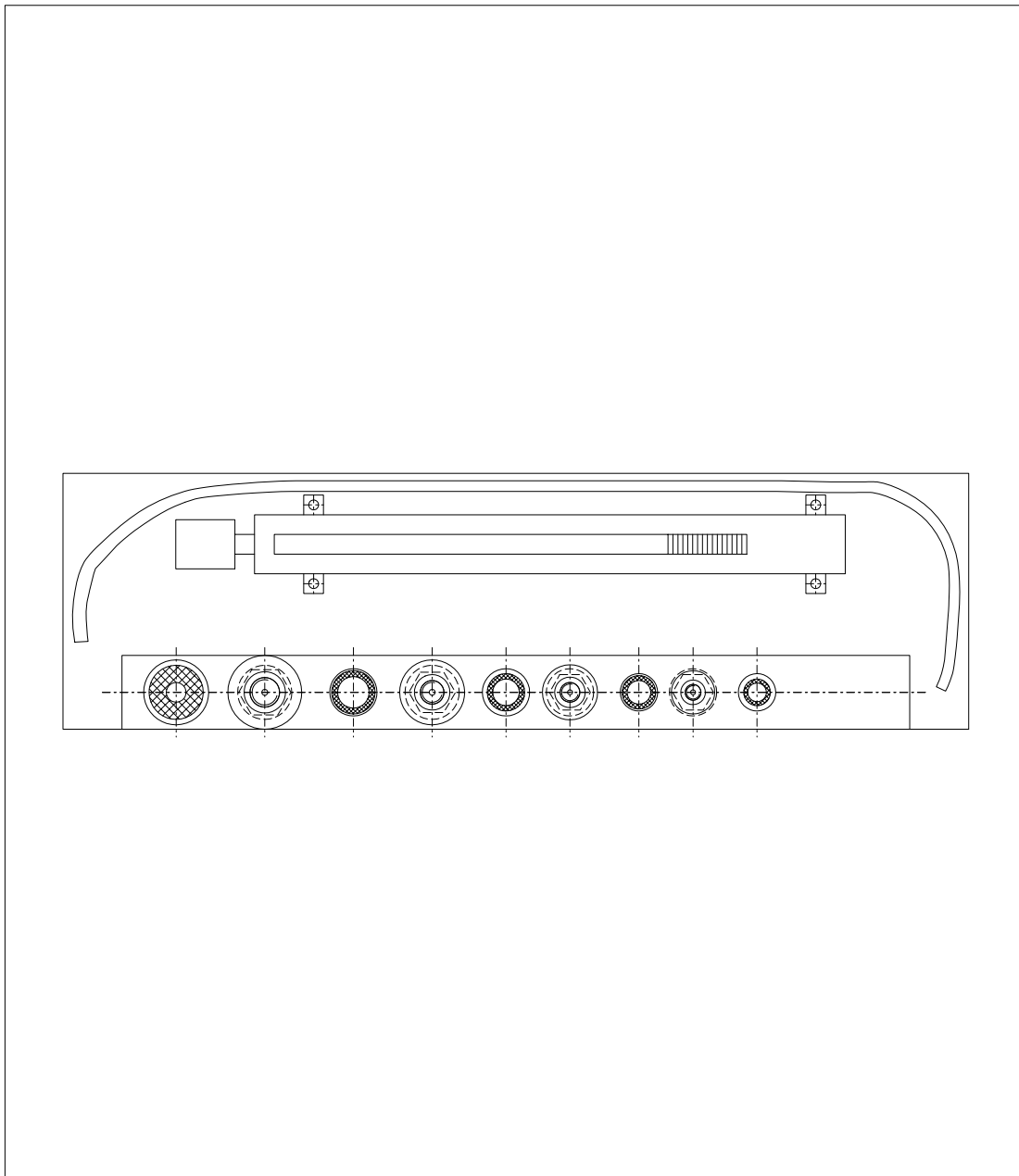

FLENDER

Caution!

Installation and start-up must be carried out by properly trained specialist personnel. Please read these operating instructions carefully before starting up. We accept no liability for personal injury or damage due to incorrect handling.

1. Demounting box

The demounting box enables the bolts (4) on RUPEX couplings to be extracted hydraulically. Fitting with a hand pump enables use at the coupling installation site and so does not require the coupling parts to be transported.

For the contents of the demounting box and assignment of the adapters to the RUPEX coupling sizes, see the diagram and the table.

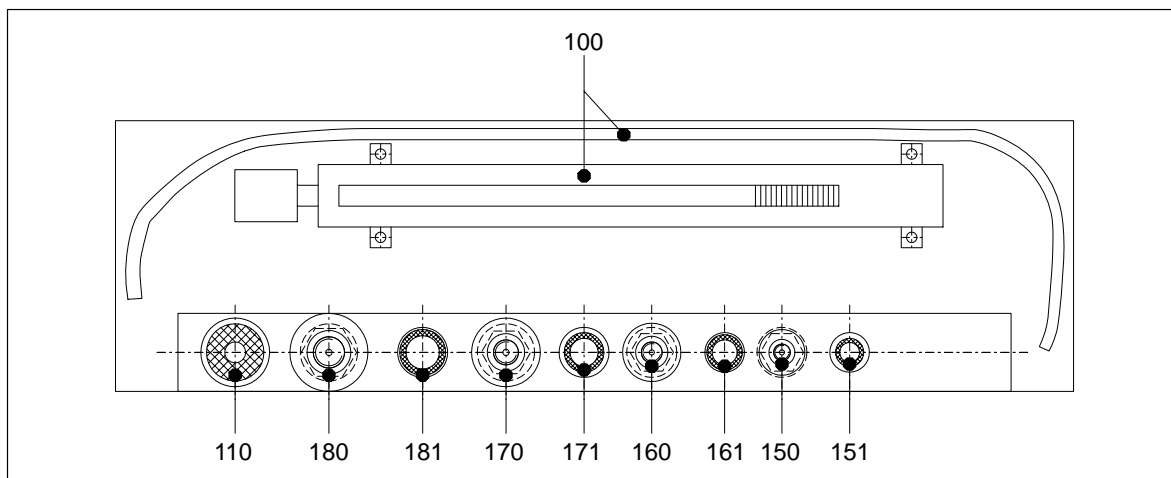

Part no.	Description	Characteristics	Qty.	RUPEX coupling size	Spanner width SW
100	Hand pump assy. cpl.	PZ216021	1	all sizes	
110	Teflon tape	12 x 0.1	1		
150	Adapter	G 1/4 M16	1	450 / 500	36
151	Gasket	17 x 22 x 1.5	10		
160	Adapter	G 1/4 M20	1	560 / 630	36
161	Gasket	21 x 27 x 1.5	10		
170	Adapter	G 1/4 M24	1	710 / 800 / 900 / 1000	41
171	Gasket	26 x 32 x 2	10		
180	Adapter	G 1/4 M30	1	1120 / 1250 / 1400 / 1600	46
181	Gasket	30 x 36 x 2	10		

Table 1: Contents of demounting box and assignment of the adapters to the RUPEX coupling sizes

2. Extraction of the RUPEX bolts

Note: The demounting device can be used only on bolts (4) which are designed with an oil hole as described in item 4. These bolts (4) are marked with the letter "O" or a groove on the end face on the buffer side.

Separate the coupling halves (1/2). Care must be taken that there is adequate working space available. From coupling size 710 upwards the locking rings (12) and disks (6) can be removed and the buffers (5) pulled off the bolts (4), if a separation of the coupling halves (1/2) is not possible.

FLENDER

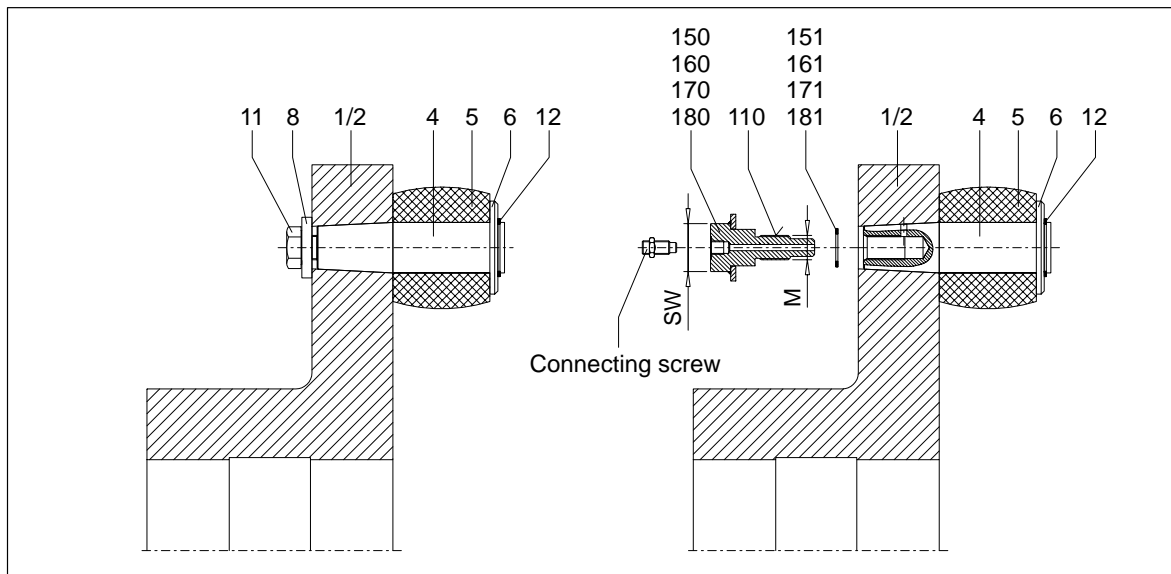

The extraction of the bolts (4) is identical on both versions.

Unscrew screw (11) and remove disk (8). Completely remove Loctite residue from the tapped hole.

Select gasket (151, 161, 171 or 181) and adapter (150, 160, 170 or 180) from table 1 to fit the RUPLEX coupling size.

Wind the Teflon strip (110) around the thread of the adapter and screw the adapter together with the gasket into the bolt (4).

Caution!

Do not use an impact screwdriver. Use only a spanner to screw in the adapter.

Then screw in the connecting screw and screw on the connector of the hand pump. Attach the connector to the hand pump.



For instructions for and information about the hand pump, refer to item 3!

Wear protective glasses!

The maximum forcing-off pressure of 1500 bar must under no circumstances be exceeded!

Danger of getting caught by the sudden movement of the adapter (150, 160, 170, 180) and sudden release of the bolt (4) !

Sudden release of the bolt is accompanied by a loud noise.

Slowly increase the pressure to enable the oil to spread evenly on the bolt (4). Several minutes may elapse between the different pressure stages. No oil must escape. Otherwise the seals must be checked.

The extraction operation has finished as soon as the bolt (4) is released from the hole.

Caution!

All the oil must be completely collected and disposed of in accordance with the regulations applying.

Then close the screw plug of the hand pump and remove the connector. Unscrew the adapter from the bolt (4), using a spanner and pliers.

Demount all the bolts (4) one after the other in this way.

If reusing the old bolts (4), clean them carefully. No Loctite etc. residues must be left in the tapped or oil holes in the bolts (4). Apply just a small quantity of Loctite to the screw (11), otherwise there is a risk that the Loctite may seal the oil hole.

When refitting, the operating instructions for the coupling must be observed.

3. Instructions for and information about the hand pump

To put in the hydraulic fluid, open the filling screw. Replace and tighten it after filling.

Open the drain valve and operate the pump a few times.

Close the drain valve and operate the pump until bubble-free fluid emerges.

Screw the hydraulic connector into the pressure connection. Make sure that the hydraulic connector is completely filled with fluid before it is attached to the cylinder. If necessary, top up fluid in the pump reservoir.

To extend the cylinder, close the drain valve on the pump and operate the pump.

To retract the cylinder, open the drain valve slowly.

To store the pump, fill the tank completely with hydraulic fluid, close the drain valve and seal the hydraulic connection.

Recommended hydraulic fluid (to DIN 51519) hydraulic fluid ISO VG 32.

To operate double-acting cylinders the pump can be equipped with a control valve. The starting position is "neutral". Screw two hydraulic connectors into the connecting threads. Make sure that the hydraulic connectors are completely filled with fluid before they are attached to the cylinder.

The pressure relief valve has been set at the factory. The setting must not be altered.

In all cases the relevant safety requirements must be observed.

4. Reworking bolt

If older RUPEX versions are extracted hydraulically in future, the bolts (4) must be provided with an oil hole as shown in the drawing and the table and must be marked with an "O" as shown in the diagram.

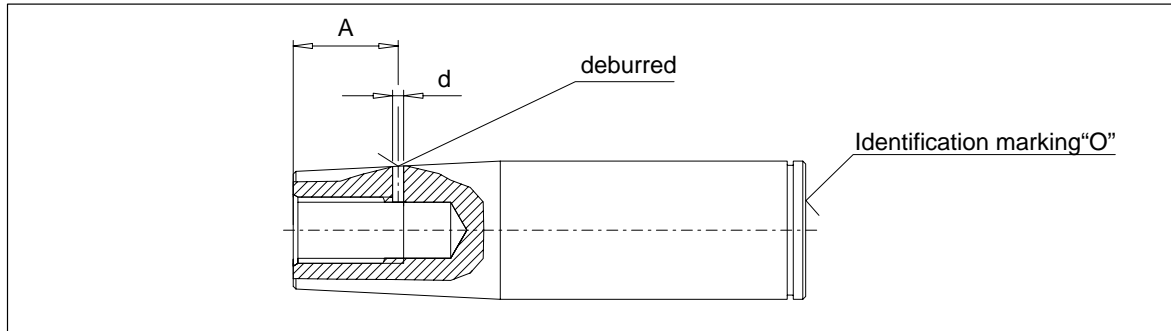

RUPEX coupling size	Distance A mm	Hole d mm
450 / 500	26	5
560 / 630	34	5
710 / 800	40	6
900 / 1000	45	6
1120 / 1250	50	6
1400 / 1600	57	6
1800 / 2000	70	8

Table 4: Location of oil hole